

# 导轨 绝缘子 母线夹

为中大型智能装备制造企业提供一站式配电器材解决方案

Wenbuluo

2026 V.1.0



200+权威认证筑就品质长城

ISO9001质量管理体系 | 高新技术认证 | CE/UL/ROHS国际认证矩阵



## 导轨/绝缘子/母线夹

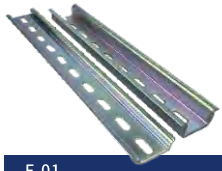

F-01  
WGG系列钢质导轨



F-02  
WLG系列铝制导轨



F-03  
导轨支架



R-57  
导轨切割机



R-58  
电动导轨切割机



F-04  
SM系列绝缘子



F-05  
MNS系列绝缘子



F-06  
HT系列绝缘子



F-07  
GGD DCS SGR系列绝缘子



F-08  
普通型配电柜绝缘子



F-09  
HT 零排支架系列



F-10  
高压绝缘子系列



F-11  
母线夹EL系列









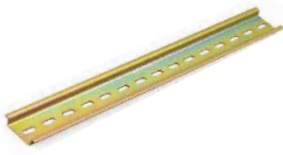
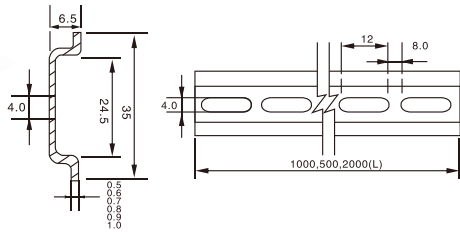

F-12  
红色母线夹

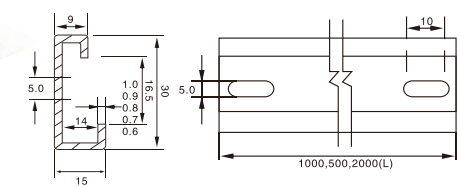
## F-01 WGG 钢质导轨

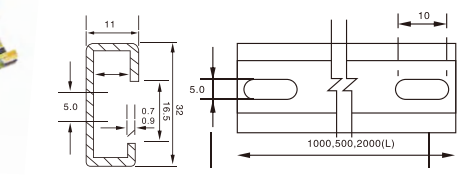
钢质导轨采用冷轧钢板，经镀锌处理，增强耐腐蚀性。  
按国际标准制作，具有外观美、精度高、强度佳等特性。  
可搭配所有符合DN规格的自控器具，适合国产及欧、美等国际标准元器件。

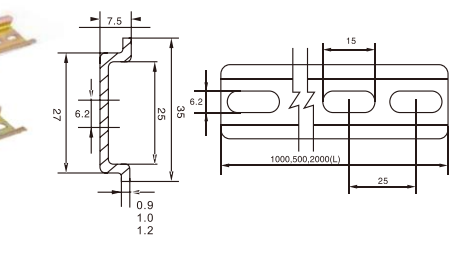
The steel guide rail is made of cold-rolled steel plate and galvanized to enhance corrosion resistance.  
Made according to international standard, it has the characteristics of beautiful appearance, accurate precision and good strength.  
It can be matched with all self-controlling devices that meet DN specifications, suitable for domestic and European, American and other international standard components.

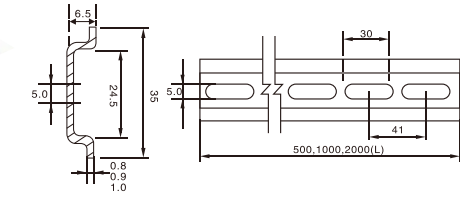
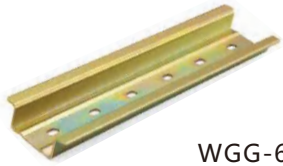
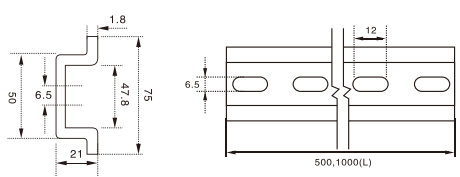
 <p>WGG-1</p>		<b>型号 Item</b>	<b>WGG-1(TH35-6.5)</b>
		厚度 Thickness	0.5/0.6/0.7/0.8/0.9/1.0/1.2/1./1.2/1.5
		孔型可提供 Pass available	4.2*12 5.5*25 5.2*30 6.2*15
		常规长度 Common length	TH35-6.5/1米 TH35-6.5/2米 其他特殊长度可定制
 <p>WGG-2</p>		<b>型号 Item</b>	<b>WGG-2(TH30-15/9)</b>
		厚度 Thickness	0.6/0.7/0.8/0.9/1.0
		孔型可提供 Pass available	5.0*10
		常规长度 Common length	TH30-15/9 1米 TH30-15/9 2米 其他特殊长度可定制
 <p>WGG-3</p>		<b>型号 Item</b>	<b>WGG-3(TH30-11)</b>
		厚度 Thickness	0.7/0.9/1.0
		孔型可提供 Pass available	5.0*10
		常规长度 Common length	TH30-11 1米 TH30-11 2米 其他特殊长度可定制
 <p>WGG-4</p>		<b>型号 Item</b>	<b>WGG-4(TH35-7.5)</b>
		厚度 Thickness	0.6/0.7/0.8/0.9/1.0/1.2
		孔型可提供 Pass available	4.2*12    5.5*15 5.5*25 5.2*30 6.2*15
		常规长度 Common length	TH35-7.5/1米 TH35-7.5/2米 其他特殊长度可定制
 <p>WGG-5</p>		<b>型号 Item</b>	<b>WGG-5(TH35-6.5)</b>
		厚度 Thickness	0.5/0.6/0.7/0.8/0.9/1.0
		孔型可提供 Pass available	5.5*25(普通长孔型)
		常规长度 Common length	TH35-6.5/1米 TH35-6.5/2米 其他特殊长度可定制
 <p>WGG-6</p>		<b>型号 Item</b>	<b>WGG-6(TH75-21)</b>
		厚度 Thickness	1.8/2.0
		孔型可提供 Pass available	6.5*12(Lc1大导轨)
		常规长度 Common length	TH75-21 1米 其他特殊长度可定制

## F-01 WGG 钢质导轨

钢质系列产品的原材料是采用上海宝钢冷轧钢板，经镀锌钝化处理，耐腐蚀，盐雾度测试达到GB242317(ka)标准要求。

按国际标准制作，具有外观美、精度高、强度佳等特性。





可搭配所有符合DN规格的自控制器具，适合国产及欧、美等国际标准元器件。

The raw material of steel series products is cold rolled steel sheet of Shanghai Baosteel. After galvanizing and passivation treatment, it is corrosion-resistant and salt spray test meets the requirements of gb242317 (KA)

Produced in accordance with international standards, with features such as beautiful appearance, accurate precision, and good strength.

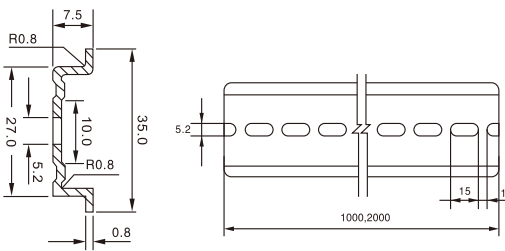
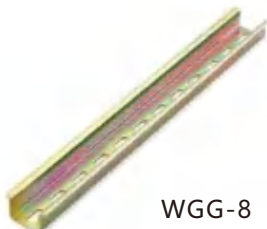
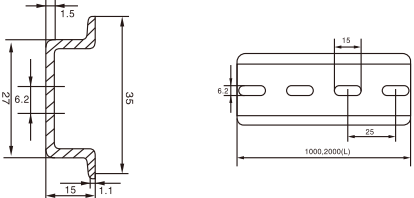
It can be matched with all self-controlling devices that meet DN specifications, suitable for domestic and European, American and other international standard components.

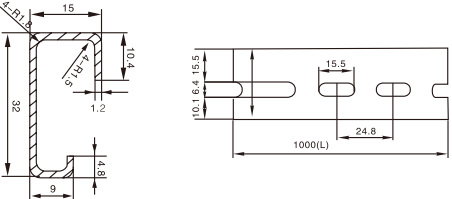
F

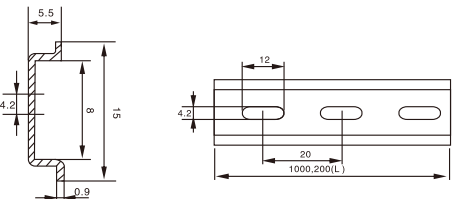
 <p>WGG-7</p>		<b>型号 Item</b>	<b>WGG-7(TH35-7.5)</b>
		厚度 Thickness	0.8 1.0(经济加强型)
		孔型可提供 Pass available	5.2*15
		常规长度 Common length	TH35-7.5(0.8)1米 TH35-7.5(0.8)2米 其他特殊长度可定制
 <p>WGG-8</p>		<b>型号 Item</b>	<b>WGG-8(TH35-15)</b>
		厚度 Thickness	1.2 1.5
		孔型可提供 Pass available	5.2*15 6.2*15
		常规长度 Common length	TH35-15(1.5)1米 TH35-15(1.5)2米 其他特殊长度可定制
 <p>WGG-9</p>		<b>型号 Item</b>	<b>WGG-9(TH35-7.5)</b>
		厚度 Thickness	1.0 1.2 (经济加强型)
		孔型可提供 Pass available	6.2*15
		常规长度 Common length	TH35-15/9(1.2)1米 TH35-15/9(1.2)2米 其他特殊长度可定制
 <p>WGG-10</p>		<b>型号 Item</b>	<b>WGG-10(TH15-5.5)</b>
		厚度 Thickness	0.9 1.0
		孔型可提供 Pass available	4.2*12
		常规长度 Common length	TH15-5.5(0.9)1米 TH15-5.5(0.9)2米 其他特殊长度可定制

## F-02 WLG 铝制导轨

铝质导轨采用普通型铝合金，经济耐用、强度保证、精度准确。

安装与拆卸快速简便，可大幅度提升效率，降低成本。

节省安装空间，满足工业自动化领域的需求。

The aluminum guide rail is made of ordinary aluminum alloy, which is economical, durable, strong and accurate.

Installation and disassembly are quick and easy, which can greatly improve efficiency and reduce costs.

Save installation space to meet the needs of industrial automation field.

<p>表面无处理 WLG-1</p>	<table border="1"> <thead> <tr> <th>型号 Item</th> <th>WLG-1(TH35-7.5)</th> </tr> </thead> <tbody> <tr> <td>厚度 Thickness</td> <td>0.7/0.9/1.1</td> </tr> <tr> <td>孔型可提供 Pass available</td> <td>4.2*15</td> </tr> <tr> <td>常规长度 Common length</td> <td>TH35-7.5/1米 TH35-7.5/2米 其他特殊长度可定制</td> </tr> </tbody> </table>	型号 Item	WLG-1(TH35-7.5)	厚度 Thickness	0.7/0.9/1.1	孔型可提供 Pass available	4.2*15	常规长度 Common length	TH35-7.5/1米 TH35-7.5/2米 其他特殊长度可定制	<table border="1"> <thead> <tr> <th>型号 Item</th> <th>WLG-1(TH35-7.5)</th> </tr> </thead> <tbody> <tr> <td>厚度 Thickness</td> <td>0.7/0.9/1.1</td> </tr> <tr> <td>孔型可提供 Pass available</td> <td>4.2*15</td> </tr> <tr> <td>常规长度 Common length</td> <td>TH35-7.5/1米 TH35-7.5/2米 其他特殊长度可定制</td> </tr> </tbody> </table>	型号 Item	WLG-1(TH35-7.5)	厚度 Thickness	0.7/0.9/1.1	孔型可提供 Pass available	4.2*15	常规长度 Common length	TH35-7.5/1米 TH35-7.5/2米 其他特殊长度可定制
型号 Item	WLG-1(TH35-7.5)																	
厚度 Thickness	0.7/0.9/1.1																	
孔型可提供 Pass available	4.2*15																	
常规长度 Common length	TH35-7.5/1米 TH35-7.5/2米 其他特殊长度可定制																	
型号 Item	WLG-1(TH35-7.5)																	
厚度 Thickness	0.7/0.9/1.1																	
孔型可提供 Pass available	4.2*15																	
常规长度 Common length	TH35-7.5/1米 TH35-7.5/2米 其他特殊长度可定制																	
<p>表面无处理 WLG-2</p>	<table border="1"> <thead> <tr> <th>型号 Item</th> <th>WLG-2(TH32-15/9)</th> </tr> </thead> <tbody> <tr> <td>厚度 Thickness</td> <td>0.7/0.9/1.1</td> </tr> <tr> <td>孔型可提供 Pass available</td> <td>无孔</td> </tr> <tr> <td>常规长度 Common length</td> <td>TH32-15/9 1米 TH32-15/9 2米 其他特殊长度可定制</td> </tr> </tbody> </table>	型号 Item	WLG-2(TH32-15/9)	厚度 Thickness	0.7/0.9/1.1	孔型可提供 Pass available	无孔	常规长度 Common length	TH32-15/9 1米 TH32-15/9 2米 其他特殊长度可定制	<table border="1"> <thead> <tr> <th>型号 Item</th> <th>WLG-2(TH32-15/9)</th> </tr> </thead> <tbody> <tr> <td>厚度 Thickness</td> <td>0.7/0.9/1.1</td> </tr> <tr> <td>孔型可提供 Pass available</td> <td>无孔</td> </tr> <tr> <td>常规长度 Common length</td> <td>TH32-15/9 1米 TH32-15/9 2米 其他特殊长度可定制</td> </tr> </tbody> </table>	型号 Item	WLG-2(TH32-15/9)	厚度 Thickness	0.7/0.9/1.1	孔型可提供 Pass available	无孔	常规长度 Common length	TH32-15/9 1米 TH32-15/9 2米 其他特殊长度可定制
型号 Item	WLG-2(TH32-15/9)																	
厚度 Thickness	0.7/0.9/1.1																	
孔型可提供 Pass available	无孔																	
常规长度 Common length	TH32-15/9 1米 TH32-15/9 2米 其他特殊长度可定制																	
型号 Item	WLG-2(TH32-15/9)																	
厚度 Thickness	0.7/0.9/1.1																	
孔型可提供 Pass available	无孔																	
常规长度 Common length	TH32-15/9 1米 TH32-15/9 2米 其他特殊长度可定制																	
<p>表面无处理 WLG-3</p>	<table border="1"> <thead> <tr> <th>型号 Item</th> <th>WLG-3(TH21-8)</th> </tr> </thead> <tbody> <tr> <td>厚度 Thickness</td> <td>0.7/0.9/1.1</td> </tr> <tr> <td>孔型可提供 Pass available</td> <td>4.2*15</td> </tr> <tr> <td>常规长度 Common length</td> <td>TH21-8/1米 TH21-8/2米 其他特殊长度可定制</td> </tr> </tbody> </table>	型号 Item	WLG-3(TH21-8)	厚度 Thickness	0.7/0.9/1.1	孔型可提供 Pass available	4.2*15	常规长度 Common length	TH21-8/1米 TH21-8/2米 其他特殊长度可定制	<table border="1"> <thead> <tr> <th>型号 Item</th> <th>WLG-3(TH21-8)</th> </tr> </thead> <tbody> <tr> <td>厚度 Thickness</td> <td>0.7/0.9/1.1</td> </tr> <tr> <td>孔型可提供 Pass available</td> <td>4.2*15</td> </tr> <tr> <td>常规长度 Common length</td> <td>TH21-8/1米 TH21-8/2米 其他特殊长度可定制</td> </tr> </tbody> </table>	型号 Item	WLG-3(TH21-8)	厚度 Thickness	0.7/0.9/1.1	孔型可提供 Pass available	4.2*15	常规长度 Common length	TH21-8/1米 TH21-8/2米 其他特殊长度可定制
型号 Item	WLG-3(TH21-8)																	
厚度 Thickness	0.7/0.9/1.1																	
孔型可提供 Pass available	4.2*15																	
常规长度 Common length	TH21-8/1米 TH21-8/2米 其他特殊长度可定制																	
型号 Item	WLG-3(TH21-8)																	
厚度 Thickness	0.7/0.9/1.1																	
孔型可提供 Pass available	4.2*15																	
常规长度 Common length	TH21-8/1米 TH21-8/2米 其他特殊长度可定制																	
<p>表面氧化处理 WLG-4</p>	<table border="1"> <thead> <tr> <th>型号 Item</th> <th>WLG-4双用型</th> </tr> </thead> <tbody> <tr> <td>厚度 Thickness</td> <td></td> </tr> <tr> <td>孔型可提供 Pass available</td> <td>5.5*25</td> </tr> <tr> <td>常规长度 Common length</td> <td>TH35-7.5/1米 TH35-7.5/2米 其他特殊长度可定制</td> </tr> </tbody> </table>	型号 Item	WLG-4双用型	厚度 Thickness		孔型可提供 Pass available	5.5*25	常规长度 Common length	TH35-7.5/1米 TH35-7.5/2米 其他特殊长度可定制	<table border="1"> <thead> <tr> <th>型号 Item</th> <th>WLG-4双用型</th> </tr> </thead> <tbody> <tr> <td>厚度 Thickness</td> <td></td> </tr> <tr> <td>孔型可提供 Pass available</td> <td>5.5*25</td> </tr> <tr> <td>常规长度 Common length</td> <td>TH35-7.5/1米 TH35-7.5/2米 其他特殊长度可定制</td> </tr> </tbody> </table>	型号 Item	WLG-4双用型	厚度 Thickness		孔型可提供 Pass available	5.5*25	常规长度 Common length	TH35-7.5/1米 TH35-7.5/2米 其他特殊长度可定制
型号 Item	WLG-4双用型																	
厚度 Thickness																		
孔型可提供 Pass available	5.5*25																	
常规长度 Common length	TH35-7.5/1米 TH35-7.5/2米 其他特殊长度可定制																	
型号 Item	WLG-4双用型																	
厚度 Thickness																		
孔型可提供 Pass available	5.5*25																	
常规长度 Common length	TH35-7.5/1米 TH35-7.5/2米 其他特殊长度可定制																	
<p>表面无处理 WLG-5MBK</p>	<table border="1"> <thead> <tr> <th>型号 Item</th> <th>WLG-5MBK 小导轨</th> </tr> </thead> <tbody> <tr> <td>厚度 Thickness</td> <td>0.7/0.9/1.1</td> </tr> <tr> <td>孔型可提供 Pass available</td> <td></td> </tr> <tr> <td>常规长度 Common length</td> <td>其他特殊长度可定制</td> </tr> </tbody> </table>	型号 Item	WLG-5MBK 小导轨	厚度 Thickness	0.7/0.9/1.1	孔型可提供 Pass available		常规长度 Common length	其他特殊长度可定制	<table border="1"> <thead> <tr> <th>型号 Item</th> <th>WLG-5MBK 小导轨</th> </tr> </thead> <tbody> <tr> <td>厚度 Thickness</td> <td>0.7/0.9/1.1</td> </tr> <tr> <td>孔型可提供 Pass available</td> <td></td> </tr> <tr> <td>常规长度 Common length</td> <td>其他特殊长度可定制</td> </tr> </tbody> </table>	型号 Item	WLG-5MBK 小导轨	厚度 Thickness	0.7/0.9/1.1	孔型可提供 Pass available		常规长度 Common length	其他特殊长度可定制
型号 Item	WLG-5MBK 小导轨																	
厚度 Thickness	0.7/0.9/1.1																	
孔型可提供 Pass available																		
常规长度 Common length	其他特殊长度可定制																	
型号 Item	WLG-5MBK 小导轨																	
厚度 Thickness	0.7/0.9/1.1																	
孔型可提供 Pass available																		
常规长度 Common length	其他特殊长度可定制																	
<p>WLG-6C</p>	<table border="1"> <thead> <tr> <th>型号 Item</th> <th>WLG-6C型电缆夹导轨</th> </tr> </thead> <tbody> <tr> <td>厚度 Thickness</td> <td></td> </tr> <tr> <td>孔型可提供 Pass available</td> <td></td> </tr> <tr> <td>常规长度 Common length</td> <td>其他特殊长度可定制</td> </tr> </tbody> </table>	型号 Item	WLG-6C型电缆夹导轨	厚度 Thickness		孔型可提供 Pass available		常规长度 Common length	其他特殊长度可定制	<table border="1"> <thead> <tr> <th>型号 Item</th> <th>WLG-6C型电缆夹导轨</th> </tr> </thead> <tbody> <tr> <td>厚度 Thickness</td> <td></td> </tr> <tr> <td>孔型可提供 Pass available</td> <td></td> </tr> <tr> <td>常规长度 Common length</td> <td>其他特殊长度可定制</td> </tr> </tbody> </table>	型号 Item	WLG-6C型电缆夹导轨	厚度 Thickness		孔型可提供 Pass available		常规长度 Common length	其他特殊长度可定制
型号 Item	WLG-6C型电缆夹导轨																	
厚度 Thickness																		
孔型可提供 Pass available																		
常规长度 Common length	其他特殊长度可定制																	
型号 Item	WLG-6C型电缆夹导轨																	
厚度 Thickness																		
孔型可提供 Pass available																		
常规长度 Common length	其他特殊长度可定制																	

## F-02 WLG 铝制导轨/ F-03 导轨支架

铝质导轨采用高强度铝合金，经氧化处理，增加强度及耐腐蚀性。

按国际标准制作，具有外观美、精度高、强度佳等特性。

可搭配所有符合DN规格的自控制器具，适合国产及欧、美等国际标准元器件。

The aluminum guide rail is made of high-strength aluminum alloy, which has been oxidized to increase strength and corrosion resistance.

Made according to international standard, it has the characteristics of beautiful appearance, accurate precision and good strength.

It can be matched with all self-controlling devices that meet DN specifications, suitable for domestic and European and American and other international standard components.

F

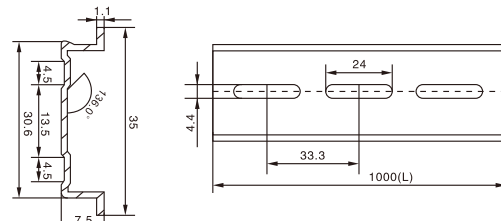
 <p>WLG-7</p>		<b>型号 Item</b>	<b>WLG-7(TH35-7.5)</b>
		厚度 Thickness	1.0/1.1/1.2/1.5
		孔型可提供 Pass available	4.2*25
		常规长度 Common length	TH35-7.5(1.1)1米 TH35-7.5(1.1)2米 其他特殊长度可定制

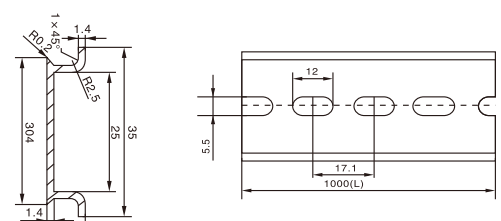
 <p>WLG-8</p>		<b>型号 Item</b>	<b>WLG-8(TH35-7.5)</b>
		厚度 Thickness	1.0/1.1/1.5
		孔型可提供 Pass available	5.2*15
		常规长度 Common length	TH35-7.5(1.4)1米 TH35-7.5(1.4)2米

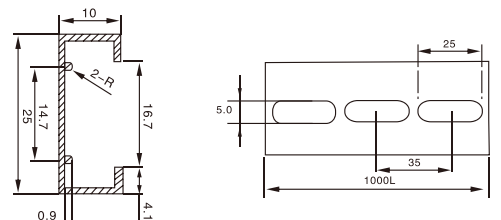
 <p>WLG-9</p>		<b>型号 Item</b>	<b>WLG-9(TH25-10)</b>
		厚度 Thickness	0.9/1.0/1.1/1.2
		孔型可提供 Pass available	5.2*25
		常规长度 Common length	TH25-10(0.9)1米 TH25-10(0.9)2米 其他特殊长度可定制

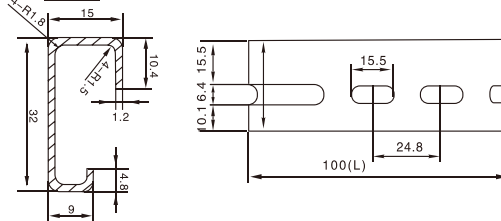
 <p>WLG-10</p>		<b>型号 Item</b>	<b>WLG-10(TH32-15/9)</b>
		厚度 Thickness	0.8/1.0/1.2
		孔型可提供 Pass available	6.5*15
		常规长度 Common length	TH32-15/9(1.2)1米 TH32-15/9(1.2)2米

	型号	规格	全长 L1	安装孔中心距 L2	高度 H	宽度 W	压线螺丝	材质
	三角导轨托架	2x20	88	61	46	20	M5	铁
		大电流铜排铁架	3x25	127	96	25	25	φ 10.5
3x30		135	104	31	30	φ 12.5	铁	

## F-04 SM 系列绝缘子

嵌入配件: 黄铜, 铁。

产品材质: 不饱和聚酯树脂玻璃纤维增强模压塑件(BMC)

工作温度: -40°C至140°C

其他: 颜色, 嵌入配件, 材料性能, 螺纹可定制。

Insert: Brass. Steel with ZN coating

Materials: BMC(Bough Moulding Compound)

Protection degree: P68-10Bar

Working temperature: -40°C to 140°C

Others: Color, Insert, Material in capability accordance screw with customer needs.

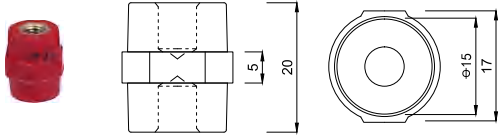
	型号(mm) Item	SM-20
	伸缩强度 (LBS) Tensile strength(LBS)	300
	耐压(KV) Voltage withstand(KV)	5
	扭矩(FTLBS) Torgue strenght(FTLBS)	4
	螺纹(mm) Screw(mm)	6
	螺纹深度(mm) Screw depth(mm)	7

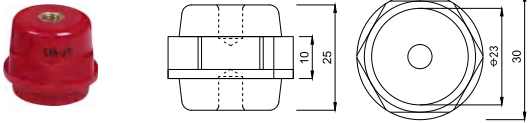
	型号(mm) Item	SM-25
	伸缩强度 (LBS) Tensile strength(LBS)	500
	耐压(KV) Voltage withstand(KV)	6
	扭矩(FTLBS) Torgue strenght(FTLBS)	6
	螺纹(mm) Screw(mm)	6(8)
	螺纹深度(mm) Screw depth(mm)	9

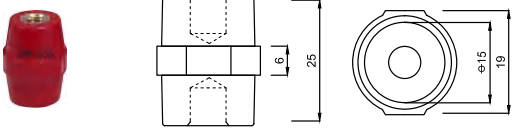
	型号(mm) Item	SM-25S
	伸缩强度 (LBS) Tensile strength(LBS)	400
	耐压(KV) Voltage withstand(KV)	6
	扭矩(FTLBS) Torgue strenght(FTLBS)	5
	螺纹(mm) Screw(mm)	6
	螺纹深度(mm) Screw depth(mm)	8

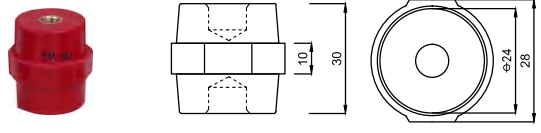
	型号(mm) Item	SM-30
	伸缩强度 (LBS) Tensile strength(LBS)	550
	耐压(KV) Voltage withstand(KV)	8
	扭矩(FTLBS) Torgue strenght(FTLBS)	8
	螺纹(mm) Screw(mm)	6
	螺纹深度(mm) Screw depth(mm)	11

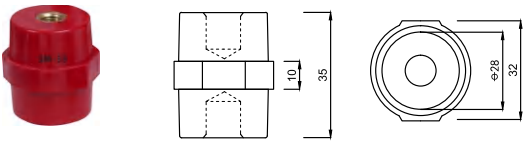
	型号(mm) Item	SM-35
	伸缩强度 (LBS) Tensile strength(LBS)	600
	耐压(KV) Voltage withstand(KV)	10
	扭矩(FTLBS) Torgue strenght(FTLBS)	10
	螺纹(mm) Screw(mm)	8
	螺纹深度(mm) Screw depth(mm)	11

F-04 SM 系列绝缘子

	<b>型号(mm) Item</b>	<b>SM-40</b>
	伸缩强度 (LBS) Tensile strength(LBS)	650
	耐压(KV) Voltage withstand(KV)	12
	扭矩(FTLBS) Torgue strenght(FTLBS)	12
	螺纹(mm) Screw(mm)	6(8)(10)
	螺纹深度(mm) Screw depth(mm)	11

	<b>型号(mm) Item</b>	<b>SM-32*30</b>
	伸缩强度 (LBS) Tensile strength(LBS)	550
	耐压(KV) Voltage withstand(KV)	8
	扭矩(FTLBS) Torgue strenght(FTLBS)	8
	螺纹(mm) Screw(mm)	6(8)
	螺纹深度(mm) Screw depth(mm)	11

	<b>型号(mm) Item</b>	<b>SM-51</b>
	伸缩强度 (LBS) Tensile strength(LBS)	1000
	耐压(KV) Voltage withstand(KV)	15
	扭矩(FTLBS) Torgue strenght(FTLBS)	20
	螺纹(mm) Screw(mm)	6(8)(10)
	螺纹深度(mm) Screw depth(mm)	11

	<b>型号(mm) Item</b>	<b>SM-60</b>
	伸缩强度 (LBS) Tensile strength(LBS)	1200
	耐压(KV) Voltage withstand(KV)	20
	扭矩(FTLBS) Torgue strenght(FTLBS)	35
	螺纹(mm) Screw(mm)	8(10)
	螺纹深度(mm) Screw depth(mm)	15

	<b>型号(mm) Item</b>	<b>SM-76</b>
	伸缩强度 (LBS) Tensile strength(LBS)	1500
	耐压(KV) Voltage withstand(KV)	25
	扭矩(FTLBS) Torgue strenght(FTLBS)	40
	螺纹(mm) Screw(mm)	10
	螺纹深度(mm) Screw depth(mm)	15

	<b>型号(mm) Item</b>	<b>SM-7100*35</b>
	伸缩强度 (LBS) Tensile strength(LBS)	500
	耐压(KV) Voltage withstand(KV)	6
	扭矩(FTLBS) Torgue strenght(FTLBS)	6
	螺纹(mm) Screw(mm)	6
	螺纹深度(mm) Screw depth(mm)	9

F-04 SM 系列绝缘子

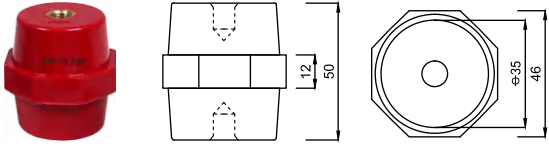
	型号(mm) Item	SM-7120A*50	
	伸缩强度 (LBS) Tensile strength(LBS)	1200	
	耐压(KV) Voltage withstand(KV)	15	
	扭矩(FTLBS) Torgue strenght(FTLBS)	12	35
	螺纹(mm) Screw(mm)	8	10
	螺纹深度(mm) Screw depth(mm)	15	15

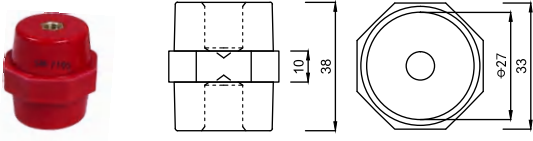
	型号(mm) Item	SM-7105*38	
	伸缩强度 (LBS) Tensile strength(LBS)	650	
	耐压(KV) Voltage withstand(KV)	8	
	扭矩(FTLBS) Torgue strenght(FTLBS)	8	
	螺纹(mm) Screw(mm)	6	
	螺纹深度(mm) Screw depth(mm)	10	

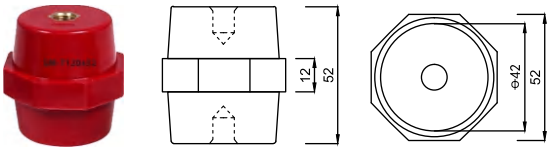
	型号(mm) Item	SM-7120*52	
	伸缩强度 (LBS) Tensile strength(LBS)	1200	
	耐压(KV) Voltage withstand(KV)	15	
	扭矩(FTLBS) Torgue strenght(FTLBS)	12	35
	螺纹(mm) Screw(mm)	10	10
	螺纹深度(mm) Screw depth(mm)	15	15

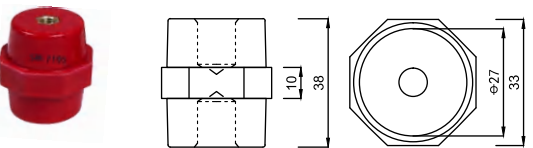
	型号(mm) Item	SM-7105*38	
	伸缩强度 (LBS) Tensile strength(LBS)	650	
	耐压(KV) Voltage withstand(KV)	8	
	扭矩(FTLBS) Torgue strenght(FTLBS)	8	
	螺纹(mm) Screw(mm)	8	
	螺纹深度(mm) Screw depth(mm)	10	

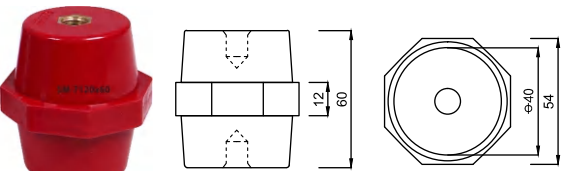
	型号(mm) Item	SM-7120*60	
	伸缩强度 (LBS) Tensile strength(LBS)	1200	
	耐压(KV) Voltage withstand(KV)	15	
	扭矩(FTLBS) Torgue strenght(FTLBS)	12	35
	螺纹(mm) Screw(mm)	10	12
	螺纹深度(mm) Screw depth(mm)	15	15

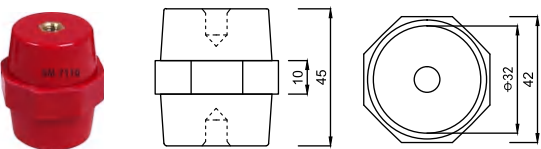
	型号(mm) Item	SM-7110*45	
	伸缩强度 (LBS) Tensile strength(LBS)	800	
	耐压(KV) Voltage withstand(KV)	10	
	扭矩(FTLBS) Torgue strenght(FTLBS)	10	
	螺纹(mm) Screw(mm)	8	
	螺纹深度(mm) Screw depth(mm)	12	

### F-04 SM 系列绝缘子

	型号(mm) Item	SM-7110*45
	伸缩强度 (LBS) Tensile strength(LBS)	800
	耐压(KV) Voltage withstand(KV)	10
	扭矩(FTLBS) Torgue strenght(FTLBS)	10
	螺纹(mm) Screw(mm)	10
	螺纹深度(mm) Screw depth(mm)	12

### F-05 MNS 系列绝缘子

嵌入配件: 黄铜, 铁。  
 产品材质: 不饱和聚酯树脂玻璃纤维增强模压塑件(BMC)  
 工作温度: -40°C至140°C  
 其他: 颜色, 嵌入配件, 材料性能, 螺纹可定制。

Insert: Brass. Steel with ZN coating  
 Materials: BMC(Bough Moulding Compound)  
 Protection degree: P68-10Bar  
 Working temperature: -40°C to 140°C  
 Others: Color, Insert, Material in capability accordance screw with customer needs.

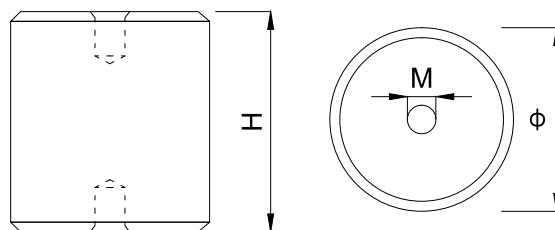

型号 Items	直径 Diameter(mm)	Values	
		高度H(mm)	内孔Screw(mm)
MNS20x30	φ 20	30	φ 6
MNS30x30	φ 30	30	φ 6 φ 8
MNS30x25	φ 30	25	φ 6
MNS30x40	φ 30	40	φ 6 φ 8
MNS40x40	φ 40	40	φ 8 φ 10
MNS40x50	φ 40	50	φ 8 φ 10
MNS40x60	φ 40	60	φ 10
MNS40x70	φ 40	70	φ 10
MNS40x80	φ 40	80	φ 10
MNS50x50	φ 50	50	φ 8 φ 10 φ 12
MNS50x60	φ 50	60	φ 10 φ 12
MNS60x40	φ 60	40	φ 8 φ 10 φ 12
MNS60x50	φ 60	50	φ 10 φ 12
MNS60x60	φ 60	60	φ 10 φ 12
MNS60x70	φ 60	70	φ 12
MNS60x80	φ 60	80	φ 12 φ 16
MNS60x90	φ 60	90	φ 12
MNS60x100	φ 60	100	φ 12 φ 16
MNS60x120	φ 60	120	φ 16

## F-06 HT 系列绝缘子

嵌入配件：黄铜，铁。  
 产品材质：不饱和聚酯树脂玻璃纤维增强模压塑件(BMC)  
 工作温度：-40°C至140°C  
 其他：颜色，嵌入配件，材料性能，螺纹可定制。

Insert: Brass. Steel with ZN coating  
 Materials: BMC(Bough Moulding Compound)  
 Protection degree: P68-10Bar  
 Working temperature: -40°C to 140°C  
 Others: Color, Insert, Material in capability accordance screw with customer needs.

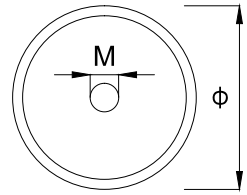
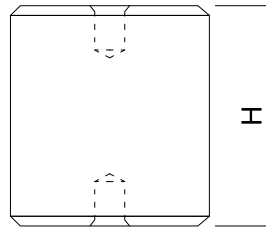

型号 Items	直径 Diameter(mm)	Values		螺母	螺杆	单头杆
		高度H(mm)	内孔Screw(mm)			
HT 80X80	φ80	80	φ10 φ12 φ16	√		
HT 80X90	φ80	90	φ10 φ12	√		
HT 80X100	φ80	100	φ10 φ12	√		
HT 65X125	φ65	125	上φ10 下φ16	√		
HT 65X130	φ65	130	上φ10 下φ16	√		
HT 65X140	φ65	140	上φ10 下φ16	√		
HT 85X140	φ85	140	上φ10 下φ16	√		
HT 85X145	φ85	145	上φ10 下φ16	√		
HT 85X150	φ85	150	上φ10 下φ16	√		
SP14	φ14	14	φ6		√	
SP24	φ20	24	φ8		√	
HT20X30	φ20	30	φ6	√		√
HT15X25(白)	φ15	25	φ5	√	√	
方型绝缘子(黄)	φ85	45	三个安装孔			
方型绝缘子(黄)	φ85	50	三个安装孔			
小高压	φ60	55	φ8			√

## F-07 GGD DCS SGR 系列绝缘子

嵌入配件：铜。

产品材质：不饱和聚酯树脂玻璃纤维增强模压塑件(BMC) PPO, ABS

工作温度：-40°C至140°C

其他：颜色，嵌入配件，材料性能，螺纹可定制。

Insert: Brass. Steel with ZN coating

Materials: BMC(Bough Moulding Compound)

Protection degree: P68-10Bar

Working temperature: -40°C to 140°C

Others: Color, Insert, Material in capability accordance screw with customer needs.



型号 Items	直径 Diameter(mm)	Values	
		高度H(mm)	内孔Screw(mm)
GGD30x40灰色	φ40	30	φ6 φ8
GGD50x50灰色	φ50	50	φ8 φ10
GCS30x40红色	φ40	30	φ6 φ8
GCS50x50红色	φ50	50	φ8 φ10
SGR30x40红色	φ40	30	φ6 φ8
SGR50x50红色	φ50	50	φ8 φ10
GGD30x40灰色大盘	φ40	30	φ6 φ8
GGD50x50灰色大盘	φ50	50	φ8 φ10
GCS30x40红色大盘	φ40	30	φ6 φ8
GCS50x50红色大盘	φ50	50	φ8 φ10
SGR30x40红色大盘	φ40	30	φ6 φ8
SGR50x50红色大盘	φ50	50	φ8 φ10
PZ30 15x25 (带杆)	φ15	25	φ5
PZ30 15x25 (铜芯)	φ15	25	φ5

## F-08 普通型配电柜绝缘子

嵌入配件：黄铜，铁。

产品材质：不饱和聚酯树脂玻璃纤维增强模压塑件(BMC)

工作温度：-40°C至140°C

其他：颜色，嵌入配件，材料性能，螺纹可定制。

Insert: Brass. Steel with ZN coating

Materials: BMC(Bough Moulding Compound)

Protection degree: P68-10Bar

Working temperature: -40°C to 140°C

Others: Color, Insert, Material in capability accordance screw with customer needs.

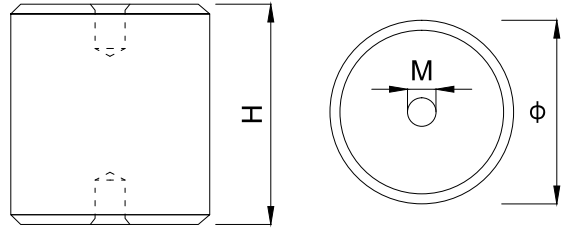

## 普通型黄色绝缘子

型号 Items	直径 Diameter(mm)	Values		螺母	螺杆	单头杆	法兰铜
		高度H(mm)	内孔Screw(mm)				
BMC 25X25	φ25	25	φ6	√	√	√	
BMC 30X30	φ30	30	φ6	√	√	√	√
BMC 35X35	φ35	35	φ8	√	√	√	
BMC 40X40	φ40	40	φ8 φ10	√	√	√	√
BMC 50X50	φ50	50	φ8 φ10 φ12	√	√	√	√
BMC 60X60	φ60	60	φ10 φ12	√	√		√

注：以上为普通型黄色绝缘子，尺寸负差 $1\pm 2$ mm，打“√”为相对应的参数。单头杆一端为螺母，另一端为螺杆。

## 国标型黄色绝缘子

型号 Items	直径 Diameter(mm)	Values		螺母	螺杆	单头杆	法兰铜
		高度H(mm)	内孔Screw(mm)				
HT 30X30	φ30	30	φ6		√		√
HT 40X40	φ40	40	φ8 φ10		√		√
HT 50X50	φ50	50	φ8 φ10		√		√
HT 60X60	φ60	60	φ10 φ12		√		√
HT 80X80	φ75	80	φ10 φ12	√	√		

注：以上为国标型黄色绝缘子，尺寸上下无负差，打“√”为相对应的参数。

F-09 HT 零排支架系列

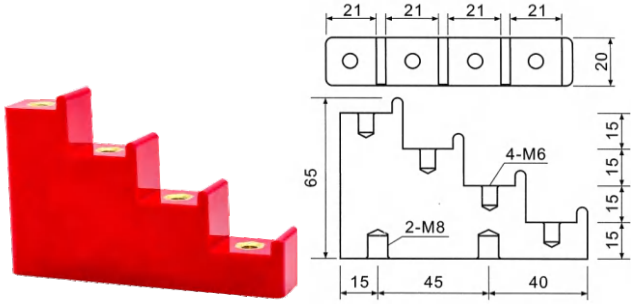

产	型	长(m)	高(m)	铜	底
H 零	H 4-2	1	6	M6	M8

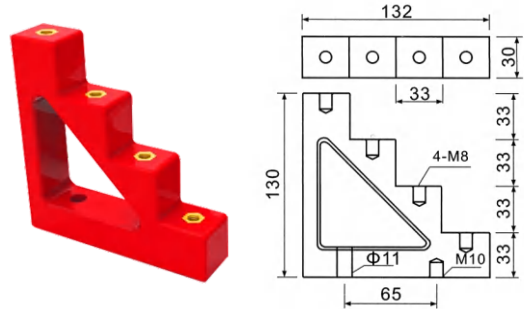

产	型	长(m)	高(m)	铜	底
H 零	H 4-3	1	1	M8	M1

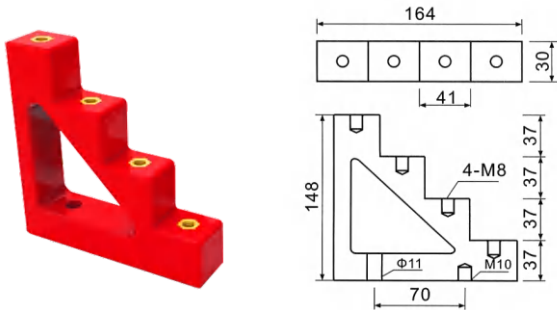

产	型	长(m)	高(m)	铜	底
H 零	H 4-4	1	1	M8	M1

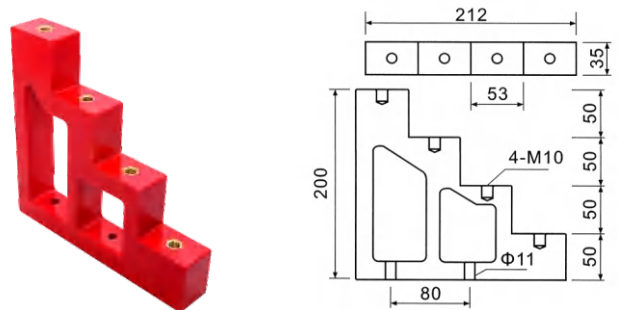

产	型	长(m)	高(m)	铜	底
H 零	H 4-5	2	2	M1	M1

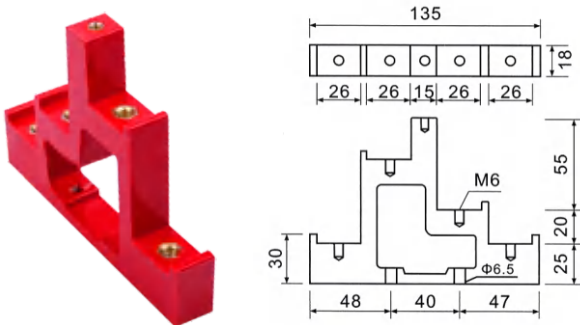

产	型	长(m)	高(m)	铜	底
H 零	H 5-2	1	1	M6	M6

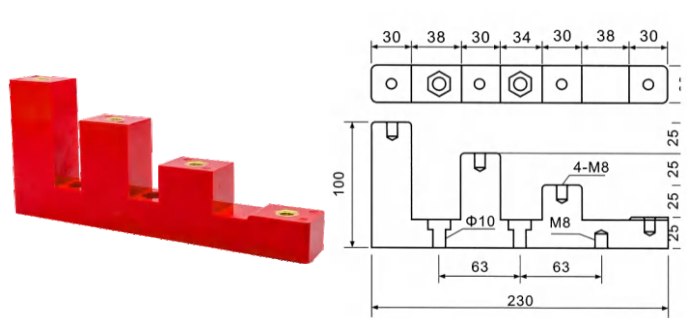

产	型	长(m)	高(m)	铜	底
H 零	H 4-3	2	1	M8	M8

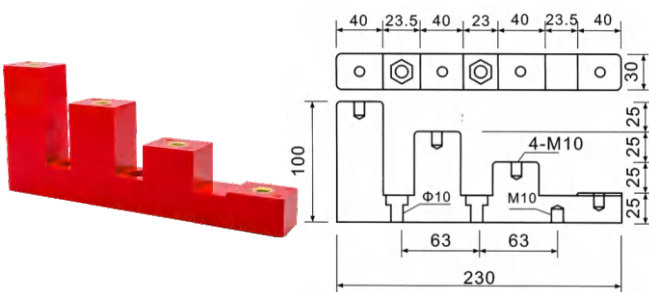

产	型	长	高	铜	底
H 零	H -4	2	1	M	M

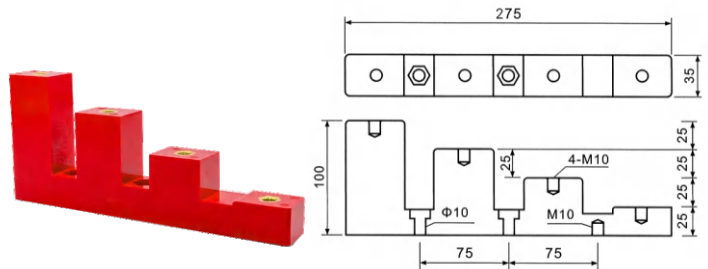

产	型	长(m)	高(m)	铜	底
H 零	H 4-5	2	1	M1	M1

F-10 高压绝缘子系列

F

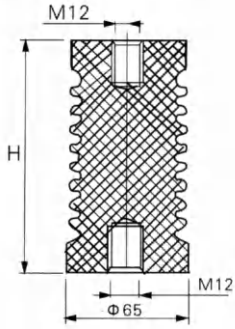

产品名称	直径	高(mm)		螺母
高压绝缘子	65	130	140	M12

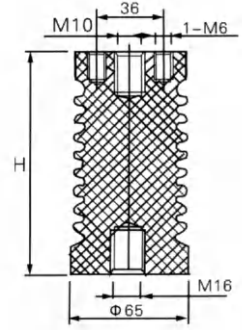

产品名称	直径	高(mm)		螺母
高压绝缘子	65	130	140	M16

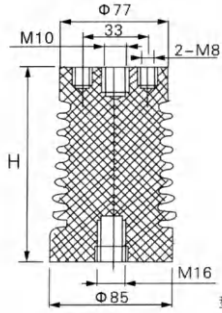

产品名称	直径	高(mm)		螺母
高压绝缘子	85	140	145	M16

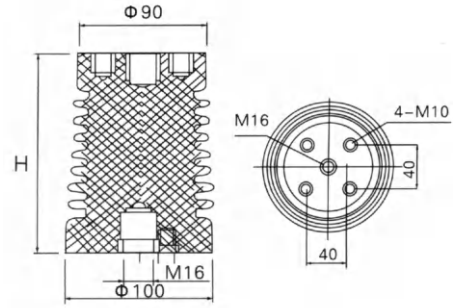

产品名称	直径	高(mm)		螺母
高压绝缘子	100	130	140	M16

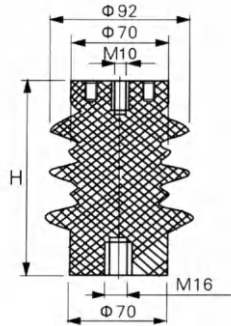

产品名称	直径	高(mm)		螺母
高压绝缘子	70	130	140	M16

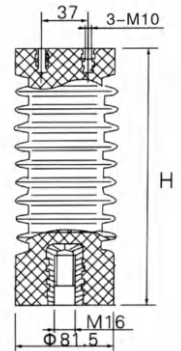

产品名称	直径	高(mm)		螺母
高压绝缘子	80	210	225	M16

F-10 高压绝缘子系列

F

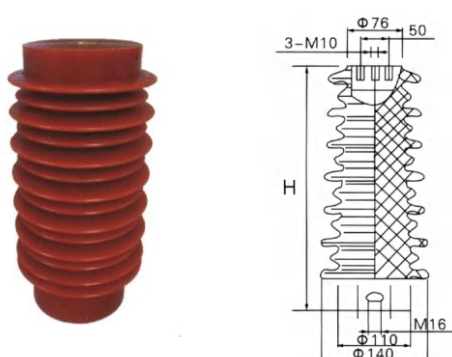
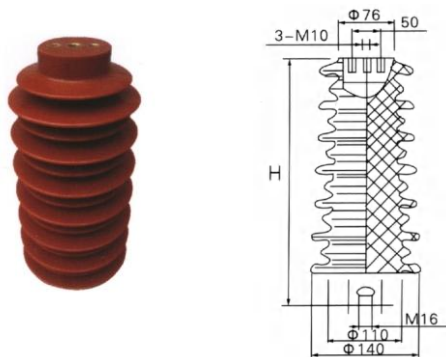

产	直	高(m )		螺
高	1	3	3	M1

产	直	高(m )		螺
高	1	3	3	M1

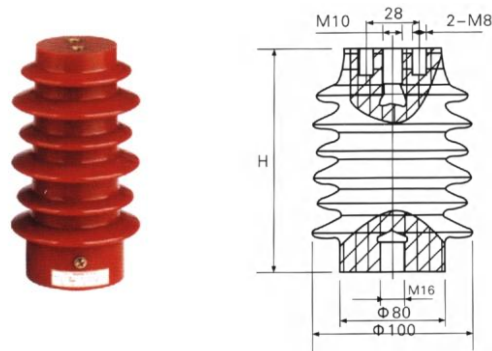
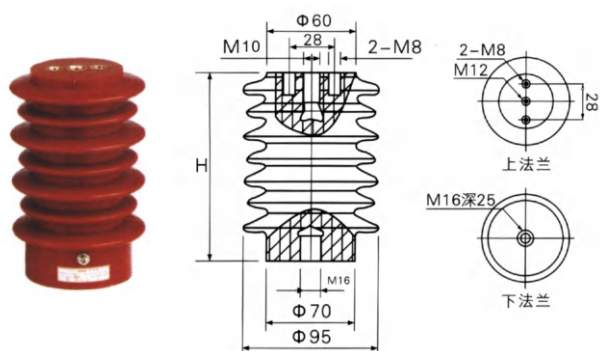

产	型	直	高(m )		
传	C 5-1 Q	9	1	/1	/1 /1

产	型	直	高(m )	
传	C 5-1 k	1	1	

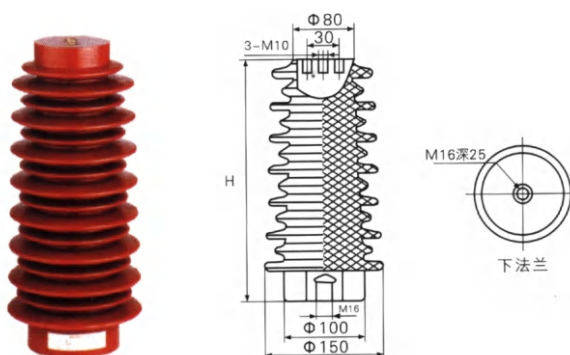
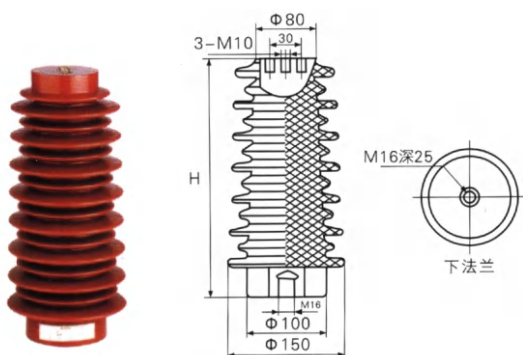

产	型	直	高(m )	
传	C 5-3 k	1	3	

产	型	直	高(m )	
传	C 5-3 k	1	3	

### F-10 高压绝缘子系列

产品材质: 不饱和聚酯树脂玻璃纤维增强压塑料  
 螺母材质: 黄铜 (各种规格可供选择)  
 试验规范: JIS C3801 and JIS C3851  
 颜色: 深棕色、深红色

Material: Bulk molding compound, unsaturated polyester  
 Nut inserts: Brass, various specifications are available  
 Test specifications: JIS C3801 and JIS C3851  
 Color: Dark brown; dark red

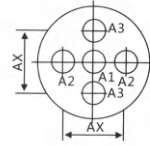

顶部 TOP

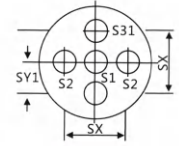
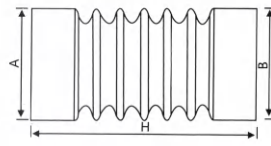

底部 BOTTOM

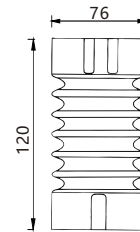

A: φ 76: 120

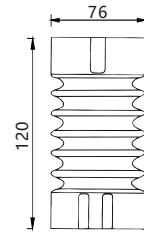

B: φ 76: 120

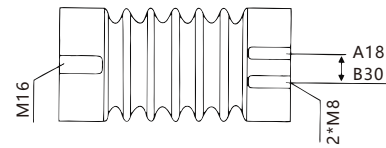

螺母型号

零件号 Part No.		76:120	EL-24	EL-15	EL-12	EL-6M	EL-3M
底部直径 End diameters (AVBj.(mm))		76	70	70	58	70	70
高度 Height(H0.mm)		120	210	142	130	90	60
表面漏电距离 Surface leakage distance, mm		300	356	210	172	125	88
额定电压 Rated voltage.kV		10	24	15	12	7.2	3.6
Low frequency dielectric strenght .kV		55	60	50	36	22	16
Impule voltage resistance,kV		110	125	110	95	75	60
Persistent begding strength lmin. kg		400	300	400	300	400	400
抗张强度 Tensile stengh, kg		>1500	>1500	>1500	>2000	>1200	>1200
扭矩强度 Torque stengthkgm		>25	>25	>25	>25	>25	>25
插孔排布 Inserts arrangement	顶部 Top	A1	M16	M10/M12	M8/M10	M10	M10
		A2	-/M8	-	-	M8	M8
		A3	-	M6/M8	M6/M8	-	-
		AX	-	-	-	36	40
		AY	-	36/40	36/40	-	-
	底部 Bottom	SI	-	M10/M12/M16	M10/M12/M16	M10/M16	M10
		S2	-	-	-	-	-
		S3	-	-	-	-	-
		S31	-	-	-	-	-
		SX	-	-	-	-	-
		SY	-	-	-	-	-
		SYI	-	-	-	-	-

F-11 母线夹EL系列

F

EL-60

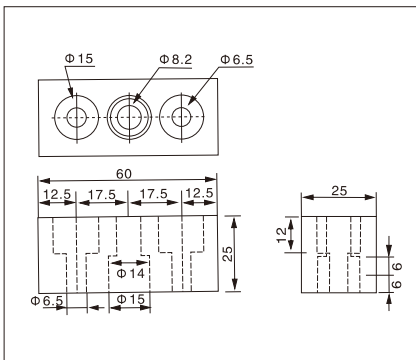

EL-105

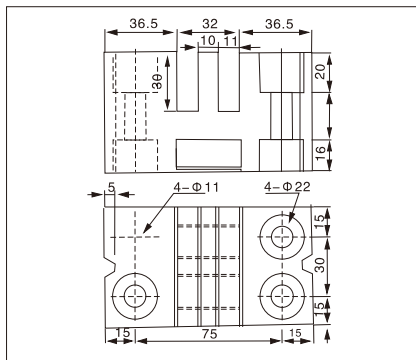

EL-130

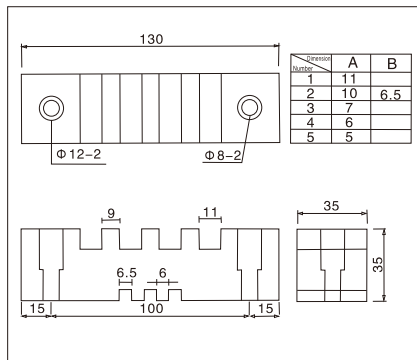

EL-155

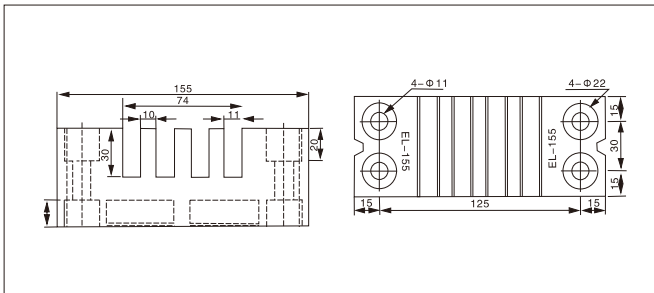

EL-170

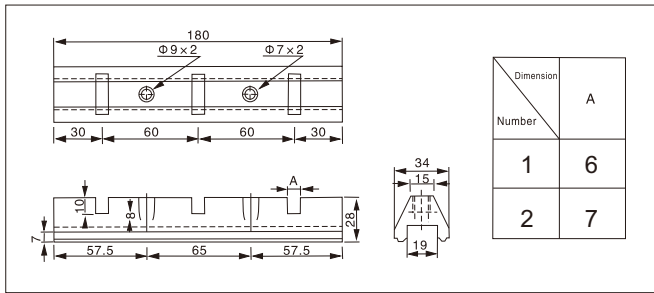

EL-180

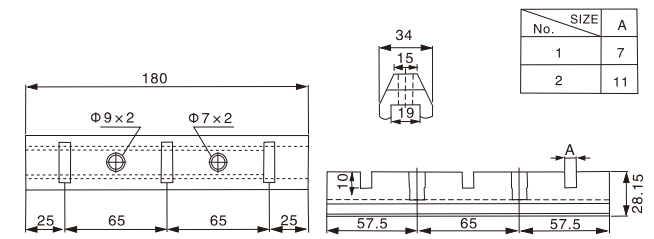

EL-210

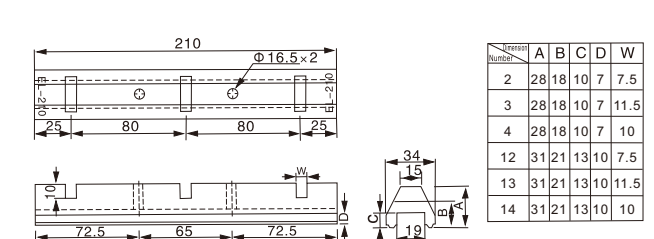
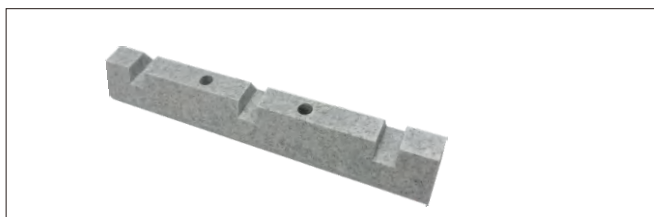

F-11母线夹EL系列

EL-270

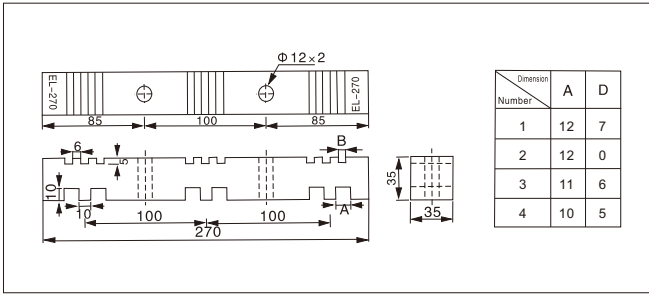

EL-295

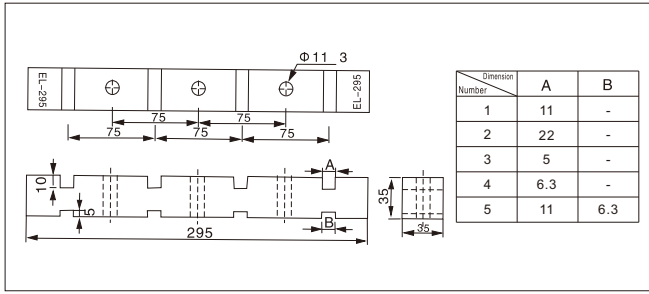
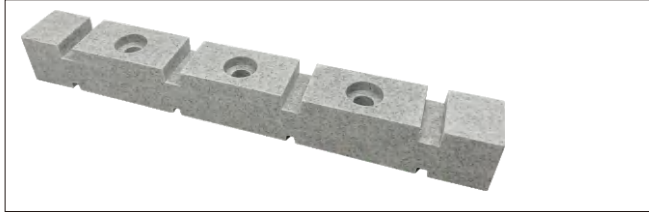

EL-409

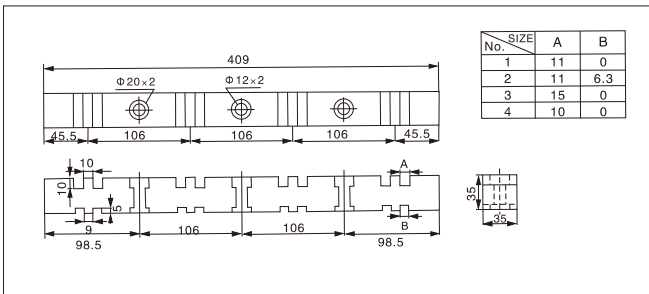
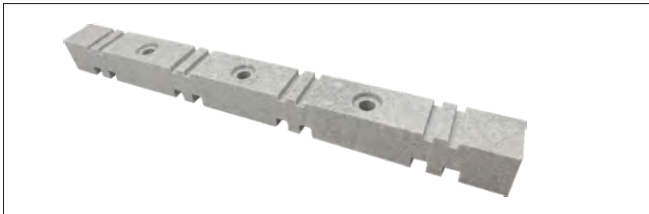

EL-500

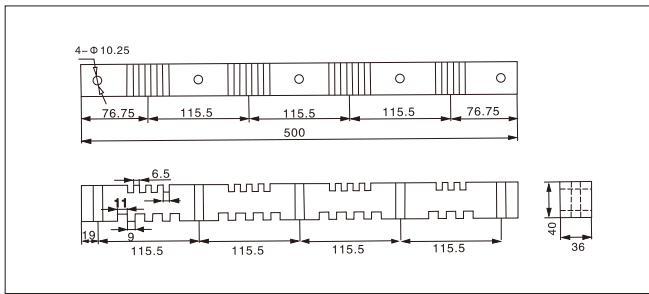

EL-600

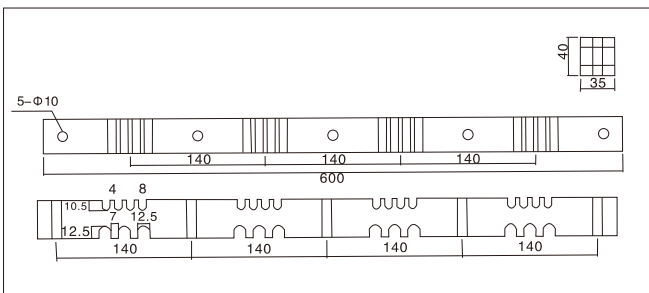

EL-800

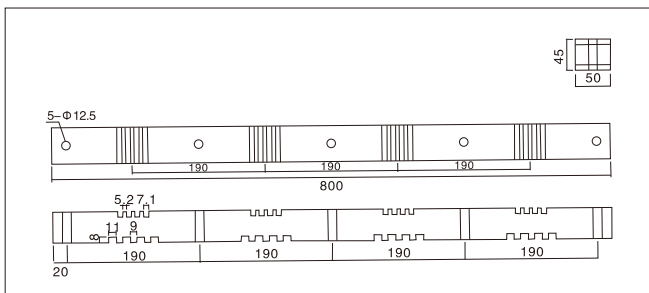
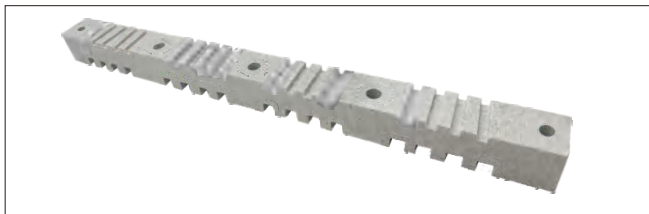

F-12 母线夹

型号(mm) Item: 6D3B 8D3B 10D3B系列 (60中心)

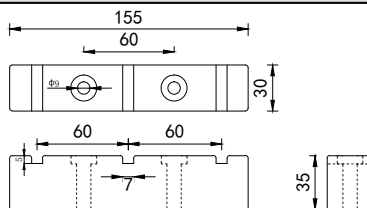

Item	A
6D3B	6
8D3B	8
10D3B	10

型号(mm) Item: 6D3 8D3 10D3系列 (80中心)

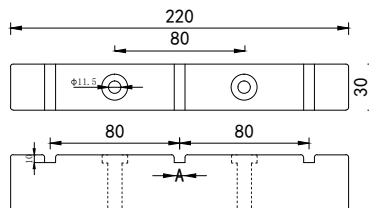

Item	A
6D3	6
8D3	8
10D3	10

型号(mm) Item: 6D4 8D4 10D4系列 (80中心)

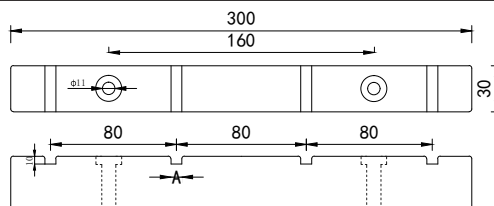

Item	A
6D4	6
8D4	8
10D4	10

型号(mm) Item: 6S3 8S3 10S3系列 (105中心)

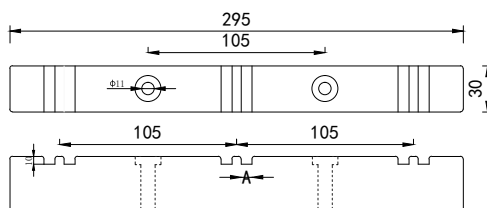

Item	A
6S3	6
8S3	8
10S3	10

型号(mm) Item: 6S4B 8S4B 10S4B系列 (93中心)

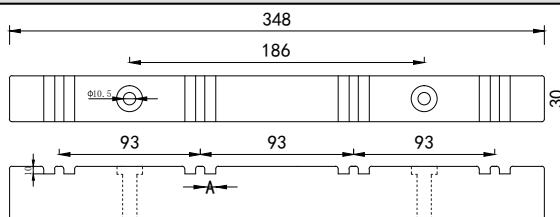

Item	A
6S4B	6
8S4B	8
10S4B	10

型号(mm) Item: 6D4 8D4 10D4系列 (105中心)

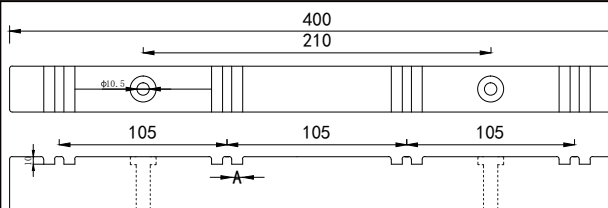

Item	A
6S4	6
8S4	8
10S4	10



线槽 | 智能照明灯 | 冷压端子 | 端子台 | 导轨 | 管件接头 | 地零排 | 绝缘母线夹 | 拖链 | 结束带  
 编织网管 | 热缩管 | Pu气管 | 扣件保护 | 标识类 | 航空插头 | 重载连接器 | 工具系列 | 风机系列

Wenbuluo

江苏稳不落配线器材有限公司  
 Wenbuluo Electrical Co., Ltd

☎ 0512-36602880

🌐 [www.wenbuluo.com](http://www.wenbuluo.com) [www.wenbuluo.cn](http://www.wenbuluo.cn)

📍 江苏省苏州市昆山市开发区熊庄路25号