

导电接地系列

为中大型智能装备制造企业提供一站式配电器材解决方案

Wenbuluo

2026 V.1.0

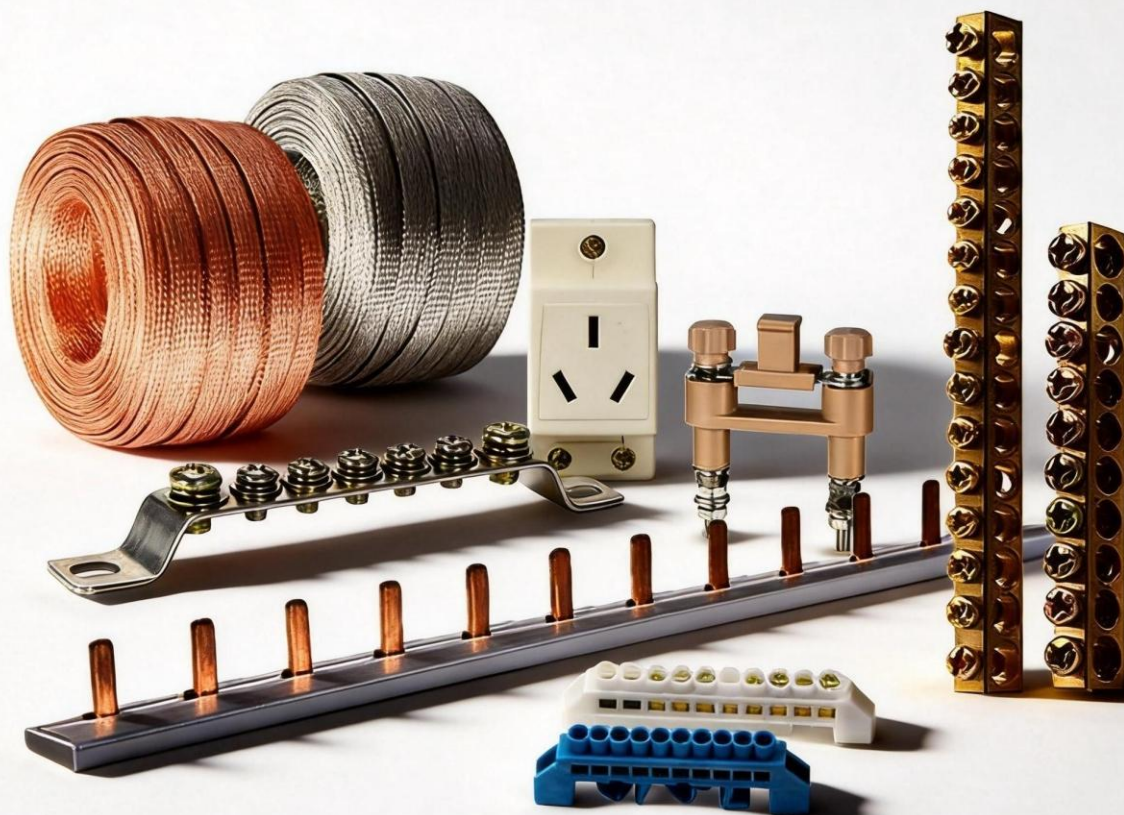

200+权威认证筑就品质长城

ISO9001质量管理体系 | 高新技术认证 | CE/UL/ROHS国际认证矩阵



导电接地系列



G-01
地零排系列

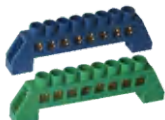

G-02
接线端子系列



G-03
铜端子系列



G-04
绝缘支架系列



G-05
汇流排



G-06
模数化插座



G-07
高压连接片



G-08
断路器桥连接



G-09
计量箱零地排



G-10
铜编织带



拖链系列



H-01
桥式系列



H-02
半封闭式



H-03
静音系列



H-04
节点封闭式

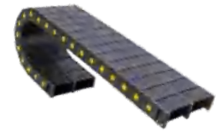

H-05
节点桥式

G-01 地零排系列



组合螺丝
WB0215A
WB0315A



内六角螺丝
WB0215A
WB0315A

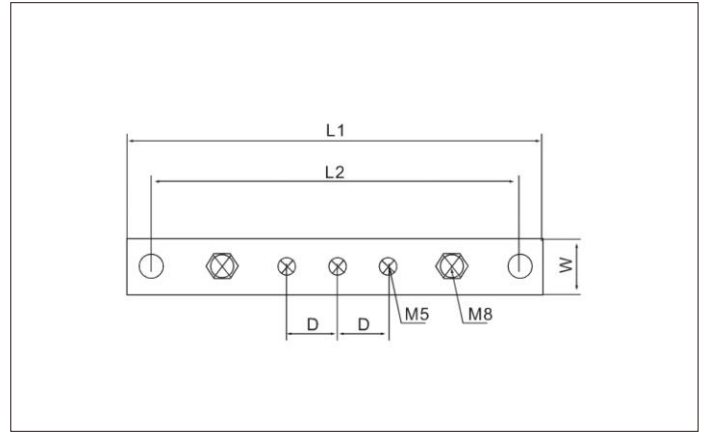

组合螺丝
WB0215B
WB0315B



内六角螺丝
WB0215B
WB0315B

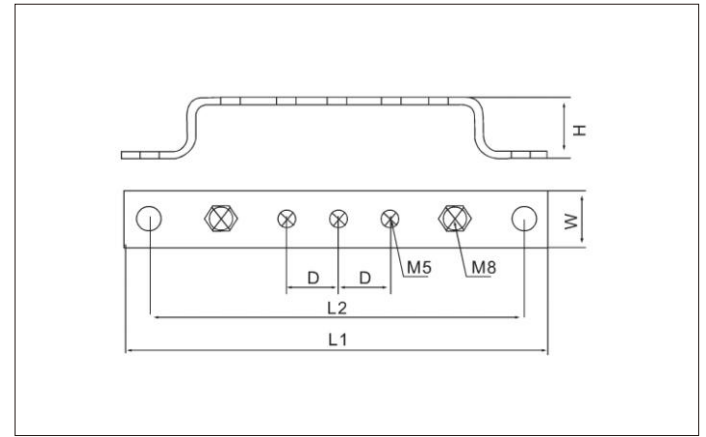

型号	规格	全长 L1	安装孔中心距 L2	间距 D	高度 H	宽度 W	压线螺丝	材质
WB0215A零排 (新型号)	2x15-5P	98	85	11	...	14	2xM8+3xM5	黄铜
	2x15-7P	120	105	11	...	14	2xM8+5xM5	黄铜
	2x15-10P	152	139	11	...	14	2xM8+8xM5	黄铜
WB0215B地排 (新型号)	2x15-5P	108	94	11	18	14	2xM8+3xM5	黄铜
	2x15-7P	131	115	11	18	14	2xM8+5xM5	黄铜
	2x15-10P	162	147	11	18	14	2xM8+8xM5	黄铜
WB0315A零排	3x15-3P	71	62	12	...	14	3xM6	黄铜
	3x15-5P	102	90	12	...	14	2xM8+3xM5	黄铜
	3x15-7P	127	112	12	...	14	2xM8+5xM5	黄铜
	3x15-10P	160	147	12	...	14	2xM8+8xM5	黄铜
WB0315B地排	3x15-3P	86	73	12	18	14	3xM6	黄铜
	3x15-5P	113	100	12	18	14	2xM8+3xM5	黄铜
	3x15-7P	136	119	12	18	14	2xM8+5xM5	黄铜
	3x15-10P	167	154	12	18	14	2xM8+8xM5	黄铜

G-01 地零排系列



组合螺丝
WB0220A
WB0320A

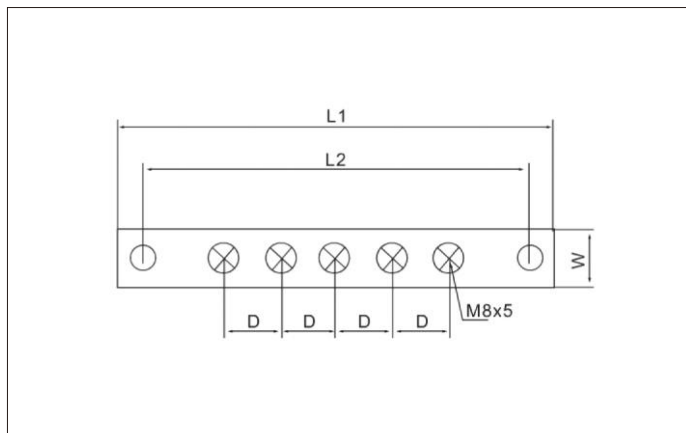

内六角螺丝
WB0220A
WB0320A



组合螺丝
WB0220B
WB0320B

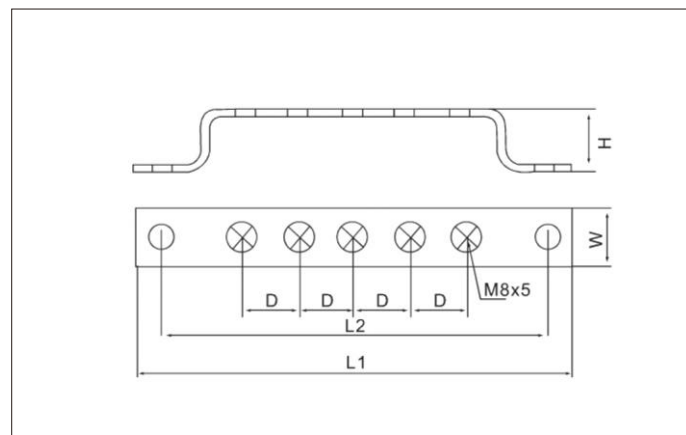

内六角螺丝
WB0220B
WB0320B

型号	规格	全长 L1	安装孔中心距 L2	间距 D	高度 H	宽度 W	压线螺丝	材质
WB0220A 零排(新型)	2x20-5P	106	92	13	...	20	2xM8+3xM6	黄铜
	2x20-7P	133	118	13	...	20	2xM8+5xM6	黄铜
	2x20-10P	174	159	13	...	20	2xM8+8xM6	黄铜
WB0220B 地排(新型)	2x20-5P	117	103	13	19	20	2xM8+3xM6	黄铜
	2x20-7P	141	127	13	19	20	2xM8+5xM6	黄铜
	2x20-10P	184	168	13	19	20	2xM8+8xM6	黄铜
WB0320A 零排	2x20-5P	110	96	14	...	20	2xM8+3xM6	黄铜
	2x20-7P	140	125	14	...	20	2xM8+5xM6	黄铜
	2x20-10P	183	167	14	...	20	2xM8+8xM6	黄铜
WB0320B 地排	2x20-5P	130	115	14	19	20	2xM8+3xM6	黄铜
	2x20-7P	160	145	14	19	20	2xM8+5xM6	黄铜
	2x20-10P	200	185	14	19	20	2xM8+8xM6	黄铜

G-01 地零排系列



组合螺丝
WB0225A
WB0325A



内六角螺丝
WB0225A
WB0325A



组合螺丝
WB0225B
WB0325B



内六角螺丝
WB0225B
WB0325B

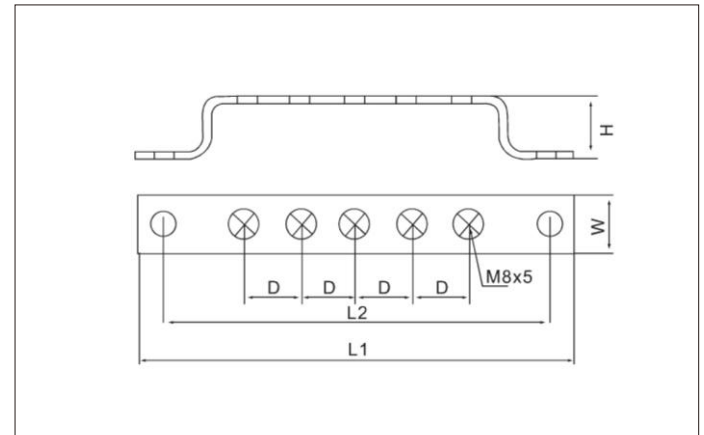
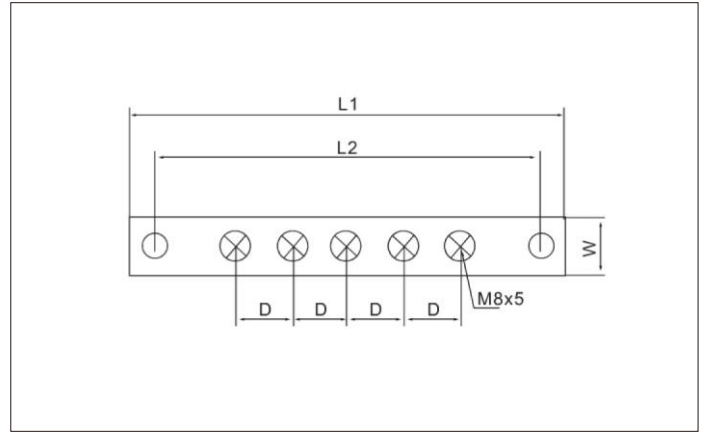

型号	规格	全长 L1	安装孔中心距 L2	间距 D	高度 H	宽度 W	压线螺丝	材质
WB0225A 零排(新型)	2x25-5P	129	111	18	...	25	5xM8	黄铜
	2x25-7P	163	145	18	...	25	7xM8	黄铜
	2x25-10P	214	195	18	...	25	10xM8	黄铜
WB0225B 地排(新型)	2x25-5P	132	114	18	22	25	5xM8	黄铜
	2x25-7P	170	152	18	22	25	7xM8	黄铜
	2x25-10P	222	205	18	22	25	10xM8	黄铜
WB0325A 零排	2x25-5P	136	118	19	...	25	5xM8	黄铜
	2x25-7P	174	155	19	...	25	7xM8	黄铜
	2x25-8P	195	176	19	...	25	8xM8	黄铜
	2x25-10P	230	210	19	...	25	10xM8	黄铜
	2x25-12P	267	248	19	...	25	12xM8	黄铜
WB0325B 地排	2x25-5P	142	125	19	22	25	5xM8	黄铜
	2x25-7P	182	165	19	22	25	7xM8	黄铜
	2x25-8P	208	185	19	22	25	8xM8	黄铜
	2x25-10P	231	213	19	22	25	10xM8	黄铜
	2x25-12P	275	255	19	22	25	12xM8	黄铜

G-01 地零排系列



组合螺丝
WB0330A

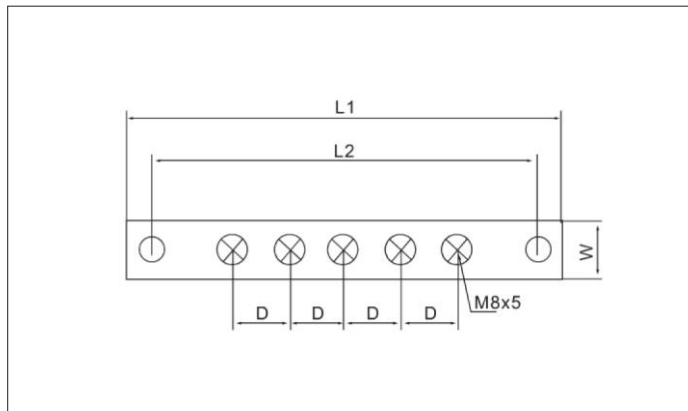

内六角螺丝
WB0330A



组合螺丝
WB0330B

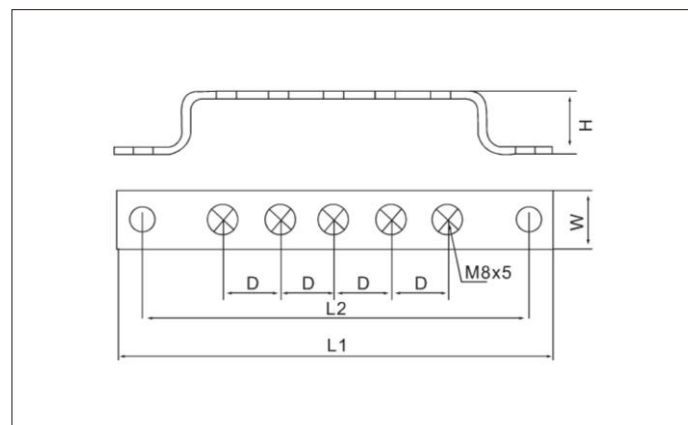

内六角螺丝
WB0330B

型号	规格	全长 L1	安装孔中心距 L2	间距 D	高度 H	宽度 W	压线螺丝	材质
WB0330A零排	3x30-5P	140	120	19	...	30	5xM8	黄铜
	3x30-7P	177	157	19	...	30	7xM8	黄铜
	3x30-8P	194	175	19	...	30	8xM8	黄铜
	3x30-10P	231	214	19	...	30	10xM8	黄铜
	3x30-12P	270	250	19	...	30	12xM8	黄铜
WB0330B地排	3x30-5P	142	124	19	22	30	5xM8	黄铜
	3x30-7P	180	162	19	22	30	7xM8	黄铜
	3x30-8P	203	185	19	22	30	8xM8	黄铜
	3x30-10P	233	212	19	22	30	10xM8	黄铜
	3x30-12P	280	255	19	22	30	12xM8	黄铜
WB0227A单层	2x27	129	108	...	8.5	27	9xM6	黄铜
WB0227A双层	2x27	129	108	...	11	27	9xM6	黄铜

WB0227A单层 (天津型)



WB0227A双层 (天津型)



G-01 地零排系列



组合螺丝 WB0325C



内六角螺丝 WB0325C

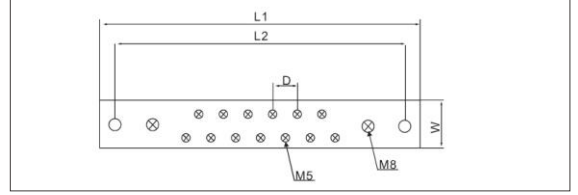

组合螺丝 WB0325D



内六角螺丝 WB0325D

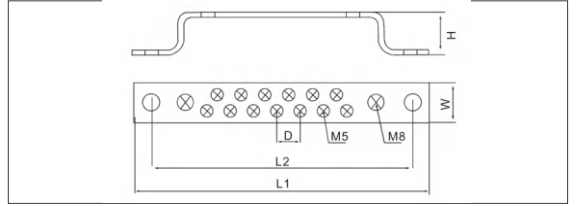

型号	规格	全长 L1	安装孔中心距 L2	间距 D	高度 H	宽度 W	压线螺丝	材质
WB0325C (零排)	3x25-11P	135	120	12	...	25	2xM8+9xM5	黄铜
	3x25-13P	150	135	12	...	25	2xM8+11xM5	黄铜
	3x25-15P	165	150	12	...	25	2xM8+13xM5	黄铜
	3x25-17P	175	160	12	...	25	2xM8+15xM5	黄铜
	3x25-19P	189	174	12	...	25	2xM8+17xM5	黄铜
	3x25-21P	202	184	12	...	25	2xM8+19xM5	黄铜
	3x25-25P	223	207	12	...	25	2xM8+23xM5	黄铜
	3x25-30P	241	225	12	...	25	2xM8+28xM5	黄铜
WB0325D (地排)	3x25-11P	149	134	12	20	25	2xM8+9xM5	黄铜
	3x25-13P	163.5	148.5	12	20	25	2xM8+11xM5	黄铜
	3x25-15P	177	164	12	20	25	2xM8+13xM5	黄铜
	3x25-17P	186	171	12	20	25	2xM8+15xM5	黄铜
	3x25-19P	200	185	12	20	25	2xM8+17xM5	黄铜
	3x25-21P	212	197	12	20	25	2xM8+19xM5	黄铜
	3x25-25P	234	220	12	20	25	2xM8+23xM5	黄铜
	3x25-30P	256	241	12	20	25	2xM8+28xM5	黄铜
WB0217A	2x20-3P	130	110	18	16	20	3xM6	黄铜
WB0214A	2x14-4P	63	...	12.5	15	31	4xM5	黄铜



WB0217A(等电位铜牌)

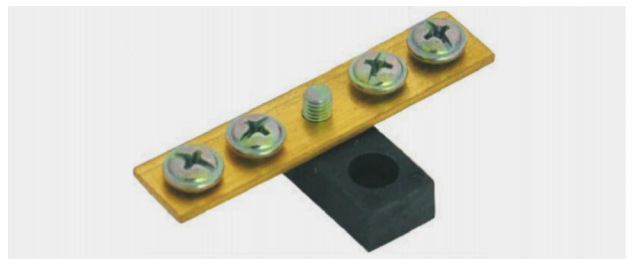

WB0214A

G-01 地零排系列



组合螺丝
WB0320C

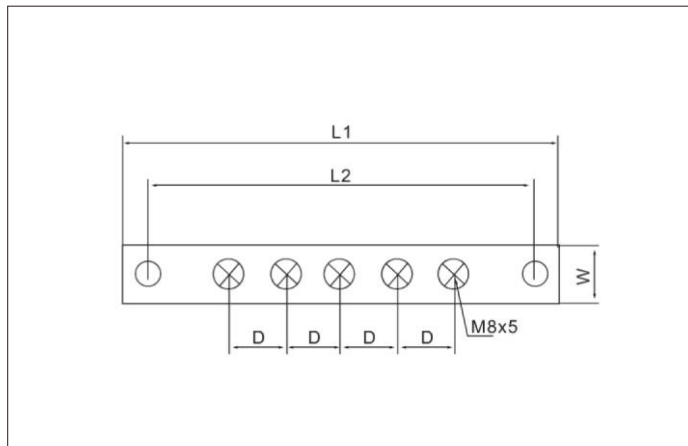

内六角螺丝
WB0320C



组合螺丝
WB0320D

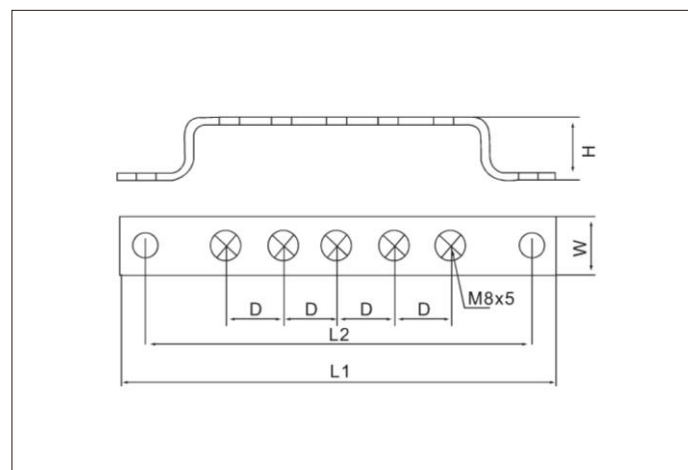

内六角螺丝
WB0320D

型号	规格	全长 L1	安装孔中心距 L2	间距 D	高度 H	宽度 W	压线螺丝	材质
WB0320C(零排)	2x20-5P	120	105	18	...	20	5xM8	黄铜
	2x20-7P	153	137	18	...	20	7xM8	黄铜
	2x20-10P	210	194	18	...	20	10xM8	黄铜
WB0320D(地排)	2x20-5P	137	121	18	20	20	5xM8	黄铜
	2x20-7P	175	160	18	20	20	7xM8	黄铜
	2x20-10P	222	205	18	20	20	10xM8	黄铜

G-02 接线端子系列

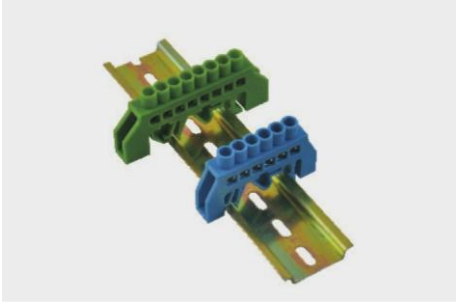

WB0609K

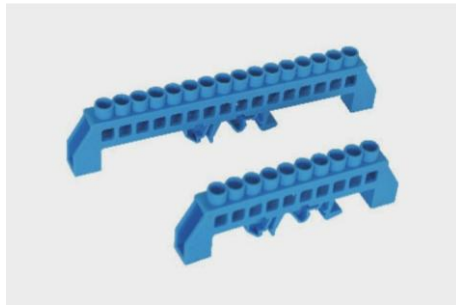
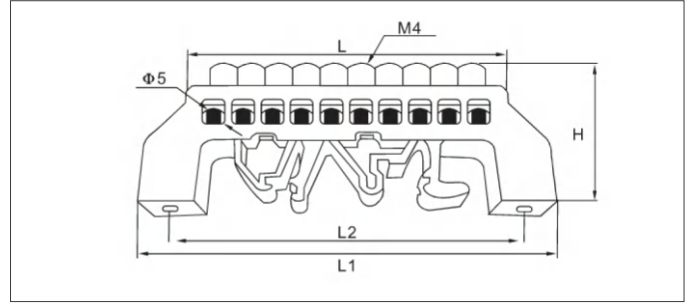

WB0812K

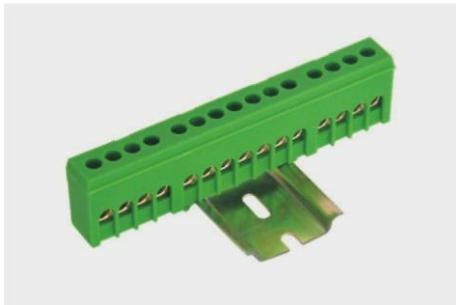
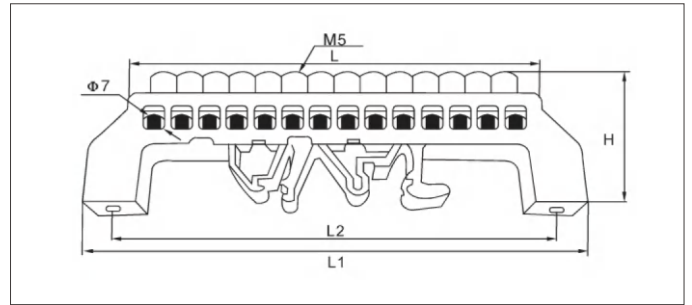

WB0609H

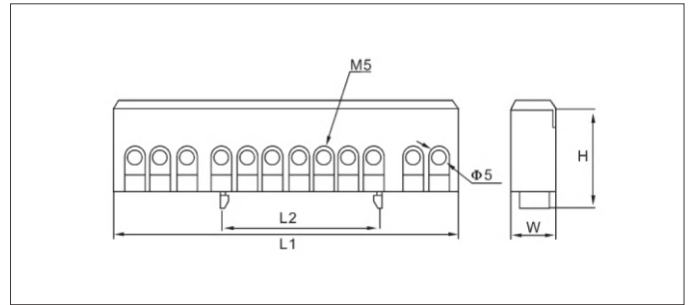

型号	规格	全长 L1	安装孔中心距 L2	铜件长度 L	高度 H	宽度 W	孔径 ϕ	压线螺丝	材质
WB0609K	6x9-4P	57	50	34	35	11	$\phi 5$	M4	黄铜
	6x9-6P	57	50	47	35	11	$\phi 5$	M4	黄铜
	6x9-8P	78	66	61	35	11	$\phi 5$	M4	黄铜
	6x9-10P	90	78	73	35	11	$\phi 5$	M4	黄铜
	6x9-12P	102	91	85	35	11	$\phi 5$	M4	黄铜
WB0812K	8x12-6P	75.5	64	52	37	12.5	$\phi 7$	M5	黄铜
	8x12-8P	92	80.5	69	37	12.5	$\phi 7$	M5	黄铜
	8x12-10P	109.2	97.7	86	37	12.5	$\phi 7$	M5	黄铜
	8x12-12P	126.8	115.3	103	37	12.5	$\phi 7$	M5	黄铜
	8x12-14P	143.7	132.2	120	37	12.5	$\phi 7$	M5	黄铜
	8x12-16P	160.5	149	137	37	12.5	$\phi 7$	M5	黄铜
WB0609H	6x9-7P	55	35	51	32	14	$\phi 5$	M5	黄铜
	6x9-10P	76	35	72	32	14	$\phi 5$	M5	黄铜
	6x9-12P	89	35	85	32	14	$\phi 5$	M5	黄铜
	6x9-15P	109	35	105	32	14	$\phi 5$	M5	黄铜

G-02 接线端子系列



WB0609F

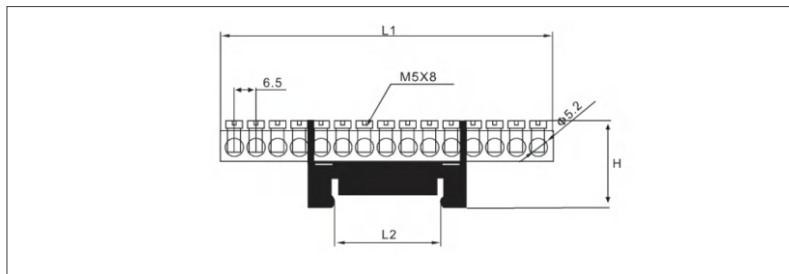

WB0609G

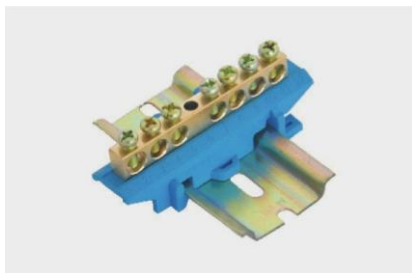
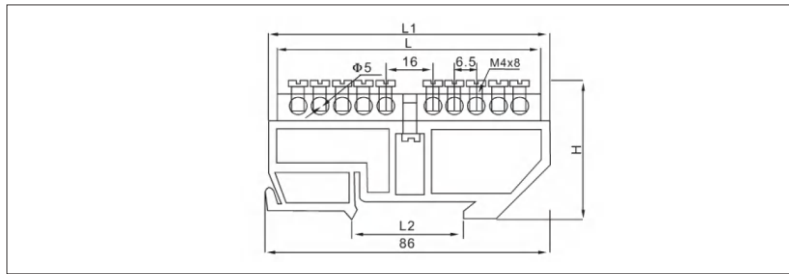

WB0609I

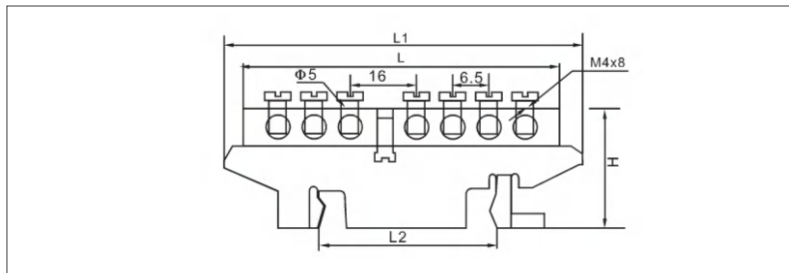

型号	规格	全长 L1	安装孔中心距 L2	铜件长度 L	高度 H	宽度 W	孔径 ϕ	压线螺丝	材质
WB0609F	6x9-7P	51	35x7.5	51	28	22	$\phi 5.5$	M5	黄铜
	6x9-8P	57	35x7.5	57	28	22	$\phi 5.5$	M5	黄铜
	6x9-10P	72	35x7.5	72	28	22	$\phi 5.5$	M5	黄铜
	6x9-12P	85	35x7.5	85	28	22	$\phi 5.5$	M5	黄铜
	6x9-13P	91	35x7.5	91	28	22	$\phi 5.5$	M5	黄铜
	6x9-15P	104	35x7.5	104	28	22	$\phi 5.5$	M5	黄铜
WB0609G	6x9-8P	86	35x7.5	57.6	43	12	$\phi 5$	M4	黄铜
	6x9-10P	86	35x7.5	70	43	12	$\phi 5$	M4	黄铜
	6x9-12P	86	35x7.5	82.4	43	12	$\phi 5$	M4	黄铜
	6x9-16P	107.2	35x7.5	107.2	43	12	$\phi 5$	M4	黄铜
	6x9-18P	119.6	35x7.5	119.6	43	12	$\phi 5$	M4	黄铜
	6x9-20P	132	35x7.5	132	43	12	$\phi 5$	M4	黄铜
WB0609I	6x9-6P	69	35x7.5	45.2	26	25	$\phi 5$	M4	黄铜
	6x9-8P	69	35x7.5	57.6	26	25	$\phi 5$	M4	黄铜
	6x9-10P	70	35x7.5	70	26	25	$\phi 5$	M4	黄铜
	6x9-12P	82.4	35x7.5	82.4	26	25	$\phi 5$	M4	黄铜
	6x9-14P	94.8	35x7.5	94.8	26	25	$\phi 5$	M4	黄铜
	6x9-16P	107.2	35x7.5	107.2	26	25	$\phi 5$	M4	黄铜

G-02 接线端子系列

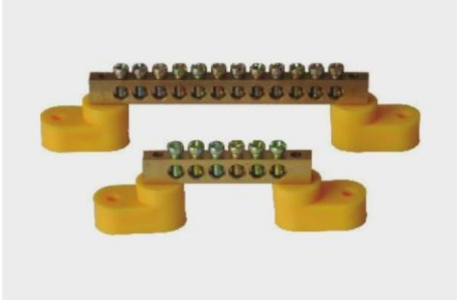

WB0609E

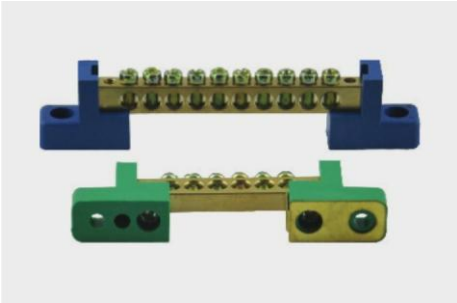
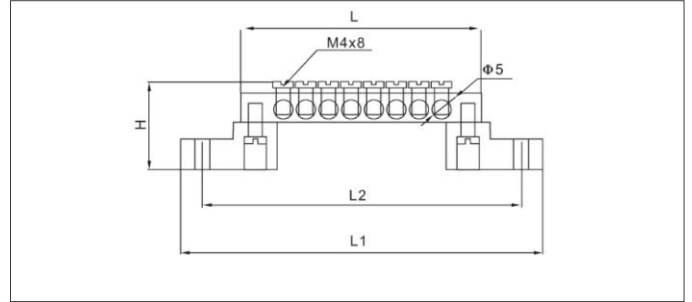

WB0609D

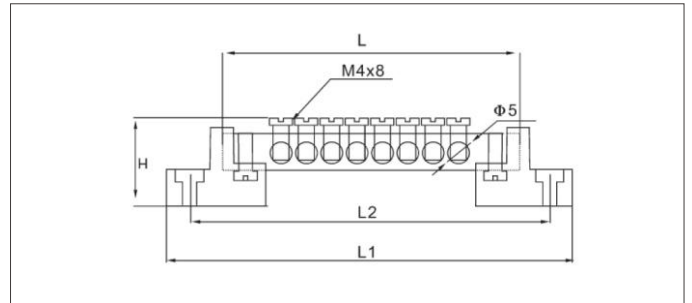

WB0609C

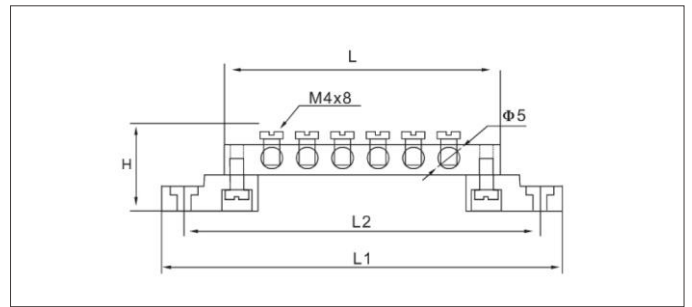

型号	规格	全长 L1	安装孔中心距 L2	铜件长度 L	高度 H	宽度 W	孔径 ϕ	压线螺丝	材质
WB0609E	6x9-4P	72	60	39	28	15	$\phi 5$	M4	黄铜
	6x9-6P	84.4	72.4	51.4	28	15	$\phi 5$	M4	黄铜
	6x9-8P	96.8	84.8	63.8	28	15	$\phi 5$	M4	黄铜
	6x9-10P	109.2	97.2	76.2	28	15	$\phi 5$	M4	黄铜
	6x9-12P	121.6	109.6	88.6	28	15	$\phi 5$	M4	黄铜
WB0609D	6x9-4P	68.8	55.5	39	22	13	$\phi 5$	M4	黄铜
	6x9-6P	81.3	68	51.4	22	13	$\phi 5$	M4	黄铜
	6x9-8P	93.8	80.5	63.8	22	13	$\phi 5$	M4	黄铜
	6x9-10P	106.3	93	76.2	22	13	$\phi 5$	M4	黄铜
	6x9-12P	118.3	105	88.6	22	13	$\phi 5$	M4	黄铜
WB0609C	6x9-4P	71	55.5	39	32	16	$\phi 5$	M4	黄铜
	6x9-6P	83.5	68	51.4	32	16	$\phi 5$	M4	黄铜
	6x9-8P	96	80.5	63.8	32	16	$\phi 5$	M4	黄铜
	6x9-10P	108.5	93	76.2	32	16	$\phi 5$	M4	黄铜
	6x9-12P	120.5	105	88.6	32	16	$\phi 5$	M4	黄铜

G-02 接线端子系列



WB0812A

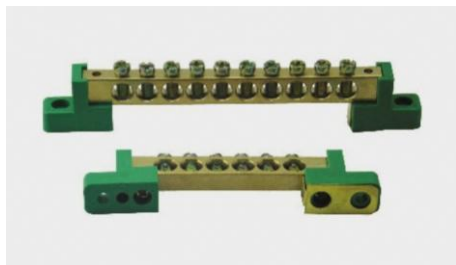
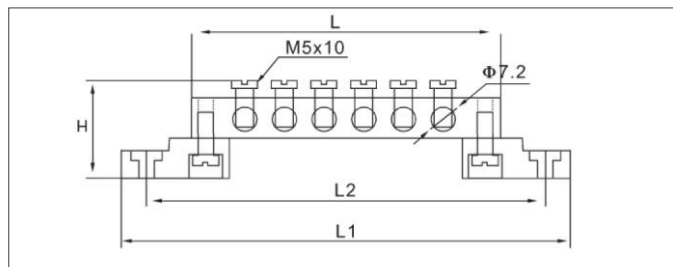

WB0812C

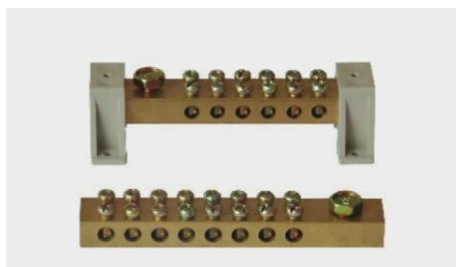
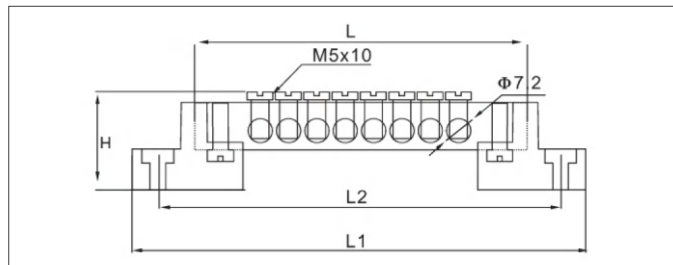

WB1218A

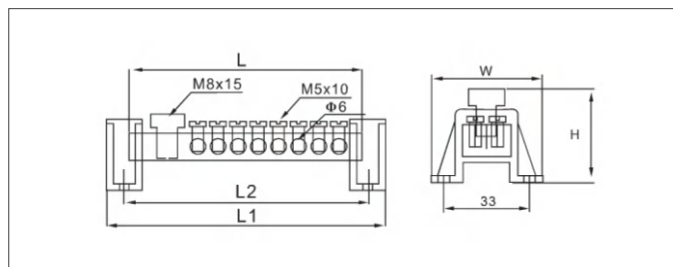

型号	规格	全长 L1	安装孔中心距 L2	铜件长度 L	高度 H	宽度 W	孔径 ϕ	压线螺丝	材质
WB0812A	8x12-4P	85	69	54	33	16	ϕ 7.5	M5	黄铜
	8x12-5P	94	78	63	33	16	ϕ 7.5	M5	黄铜
	8x12-6P	103	87	72	33	16	ϕ 7.5	M5	黄铜
	8x12-7P	112	96	81	33	16	ϕ 7.5	M5	黄铜
	8x12-8P	121	105	90	33	16	ϕ 7.5	M5	黄铜
	8x12-10P	139	123	108	33	16	ϕ 7.5	M5	黄铜
	8x12-12P	157	141	126	33	16	ϕ 7.5	M5	黄铜
WB0812C	8x12-4P	84	71	54	25	13	ϕ 7.5	M5	黄铜
	8x12-5P	93	80	63	25	13	ϕ 7.5	M5	黄铜
	8x12-6P	102	89	72	25	13	ϕ 7.5	M5	黄铜
	8x12-7P	111	98	81	25	13	ϕ 7.5	M5	黄铜
	8x12-8P	120	107	90	25	13	ϕ 7.5	M5	黄铜
	8x12-10P	138	125	108	25	13	ϕ 7.5	M5	黄铜
	8x12-12P	156	143	126	25	13	ϕ 7.5	M5	黄铜
WB1218A	12x18-4P	86	72	68	30	42	ϕ 6.5	8xM5+1xM8	黄铜
	12x18-5P	96	82	78	30	42	ϕ 6.5	10xM5+1xM8	黄铜
	12x18-6P	106	92	88	30	42	ϕ 6.5	12xM5+1xM8	黄铜
	12x18-7P	116	102	98	30	42	ϕ 6.5	14xM5+1xM8	黄铜
	12x18-8P	126	112	108	30	42	ϕ 6.5	16xM5+1xM8	黄铜
	12x18-9P	136	122	118	30	42	ϕ 6.5	18xM5+1xM8	黄铜
	12x18-10P	146	132	128	30	42	ϕ 6.5	20xM5+1xM8	黄铜
	12x18-12P	166	152	148	30	42	ϕ 6.5	24xM5+1xM8	黄铜
	12x18-15P	196	182	178	30	42	ϕ 6.5	30xM5+1xM8	黄铜
	12x18-20P	246	282	228	30	42	ϕ 6.5	40xM5+1xM8	黄铜

G-02 接线端子系列



WB0609A

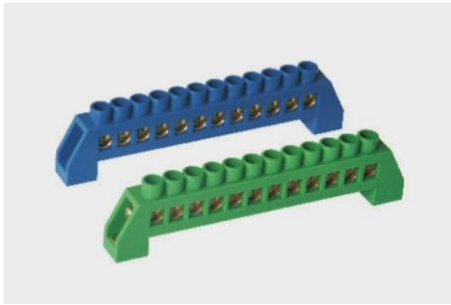
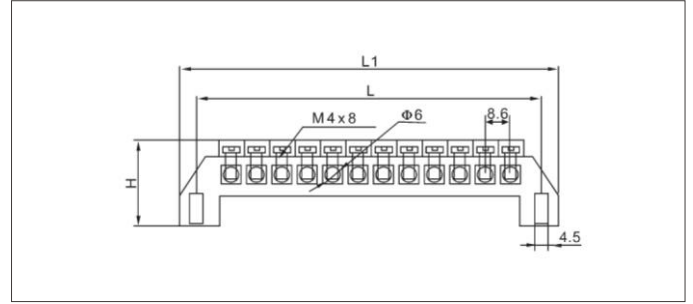

WB0812B

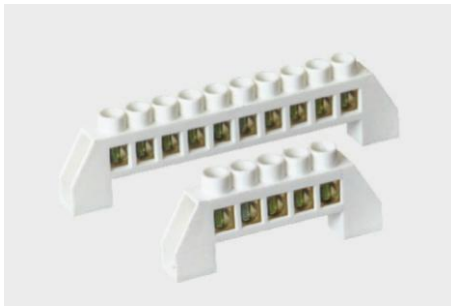
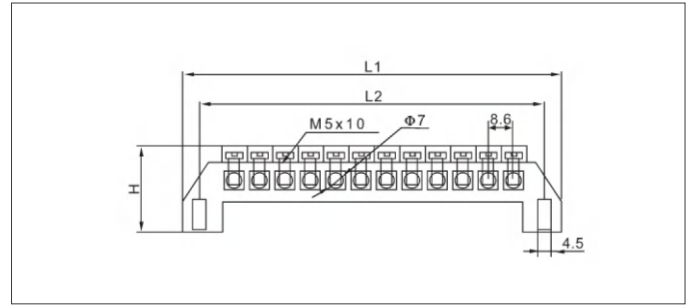

WB0812D

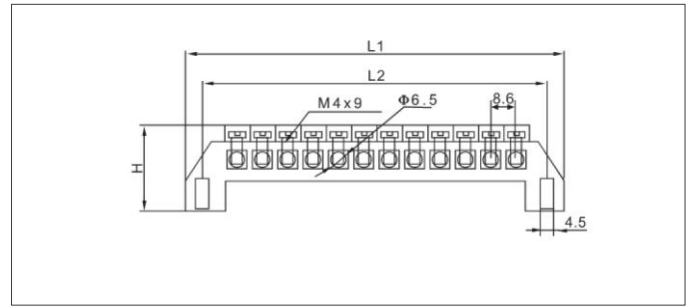

型号	规格	全长 L1	安装孔中心距 L2	高度 H	宽度 W	孔径 ϕ	压线螺丝	材质
WB0609A	6x9-4P	59.2	48.2	29.5	11	$\phi 6$	M4	黄铜
	6x9-6P	76.4	65.4	29.5	11	$\phi 6$	M4	黄铜
	6x9-8P	93.6	82.6	29.5	11	$\phi 6$	M4	黄铜
	6x9-10P	110.8	99.8	29.5	11	$\phi 6$	M4	黄铜
	6x9-12P	128	117	29.5	11	$\phi 6$	M4	黄铜
WB0812B	8x12-4P	59.2	48.2	32	12.5	$\phi 7$	M5	黄铜
	8x12-6P	76.4	65.4	32	12.5	$\phi 7$	M5	黄铜
	8x12-8P	93.6	82.6	32	12.5	$\phi 7$	M5	黄铜
	8x12-10P	110.8	99.8	32	12.5	$\phi 7$	M5	黄铜
	8x12-12P	128	117	32	12.5	$\phi 7$	M5	黄铜
WB0812D	6x9-5P	65	55	29	11	$\phi 7$	M4	黄铜
	6x9-6P	75	65	29	11	$\phi 7$	M4	黄铜
	6x9-7P	84	74	29	11	$\phi 7$	M4	黄铜
	6x9-8P	90	80	29	11	$\phi 7$	M4	黄铜
	6x9-10P	108	98	29	11	$\phi 7$	M4	黄铜
	6x9-12P	123	113	29	11	$\phi 7$	M4	黄铜

G-02 接线端子系列



WB0608B

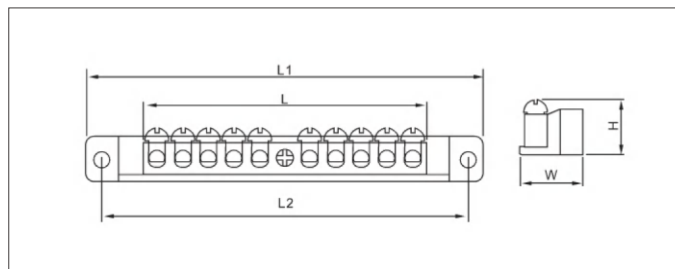

WB0711A

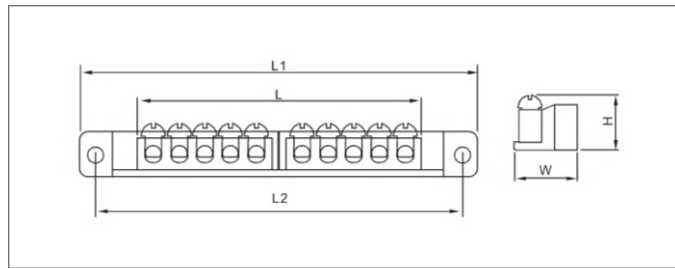

WB0710D

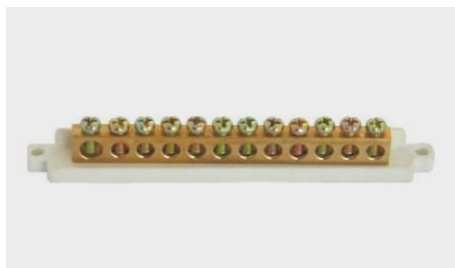
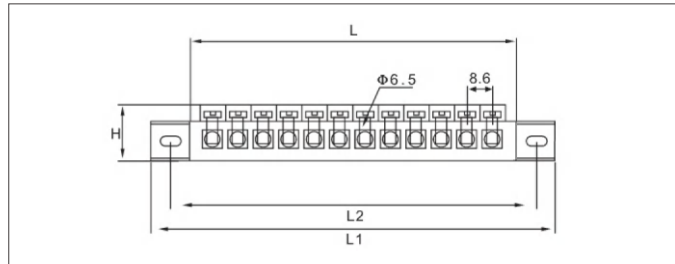

WB0610B

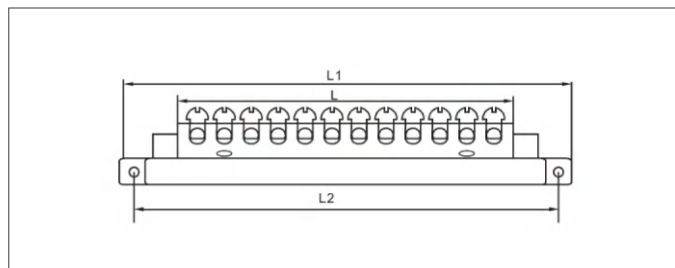

型号	规格	全长 L1	安装孔中心距 L2	铜件长度 L	高度 H	宽度 W	孔径 ϕ	压线螺丝	材质
WB0608B	3P	71.5	63	19.2	13	16	ϕ 5	M4	黄铜
	4P	71.5	63	25.6	13	16	ϕ 5	M4	黄铜
	5P	71.5	63	32	13	16	ϕ 5	M4	黄铜
	6P	71.5	63	38.4	13	16	ϕ 5	M4	黄铜
	7P	71.5	63	44.8	13	16	ϕ 5	M4	黄铜
	8P	71.5	63	51.2	13	16	ϕ 5	M4	黄铜
	10P	100.5	92.5	64	13	16	ϕ 5	M4	黄铜
WB0711A	5+5P	104	95	84	19	18	ϕ 6.5	M5	黄铜
WB0710D	6x9-5P白色	65.5	55	46	19.5	13	ϕ 6.5	M4	黄铜
	6x9-10P白色	109	98.5	89.5	19.5	13	ϕ 6.5	M4	黄铜
	6x9-10P灰色	112	101	94	19.5	14.5	ϕ 6.5	M4	黄铜
WB0610B	6x10-10P	114.5	108	74	18	11.7	1x ϕ 6.5+9x ϕ 5	M4	黄铜
	6x10-12P	114.5	108	89	18	11.7	1x ϕ 6.5+11x ϕ 5	M4	黄铜
	6x10-13P	114.5	108	96.5	18	11.7	1x ϕ 6.5+12x ϕ 5	M4	黄铜

G-02 接线端子系列



WB0609A

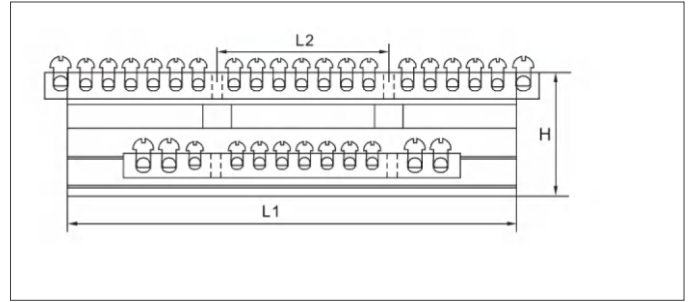

WB0812B

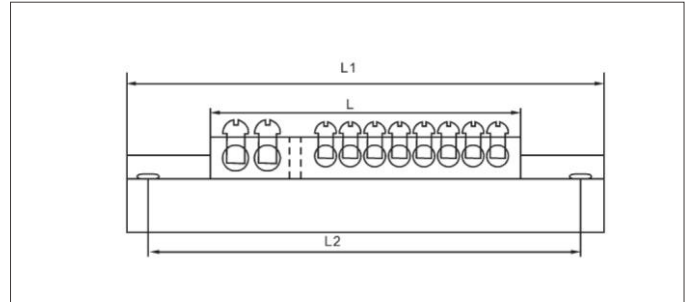

型号	规格	全长 L1	安装孔中心距 L2	铜件长度 L	高度 H	宽度 W	孔径 ϕ	压线螺丝	材质
WB6509D接地	6.5x9- 8/1	74	...	74	13	8	2x ϕ 6+6x ϕ 5.2	2xM5+6xM4	黄铜
	6.5x9-12/1	106	...	106	13	8	2x ϕ 6+10x ϕ 5.2	2xM5+10xM4	黄铜
	6.5x9-16/2	146	71.6	146	13	8	2x ϕ 6+14x ϕ 5.2	2xM5+14xM4	黄铜
	6.5x9-20/2	178	71.6	178	13	8	2x ϕ 6+18x ϕ 5.2	2xM5+18xM4	黄铜
	6.5x9-30/2	260	71.6	260	13	8	4x ϕ 6+26x ϕ 5.2	4xM5+26xM4	黄铜
WB6509D	8+8	188	151	66+66	23	25	4x ϕ 6+12x ϕ 5.2	4xM5+12xM4	黄铜
	8+12	188	151	66+98	23	25	4x ϕ 6+16x ϕ 5.2	4xM5+16xM4	黄铜
	12+12	188	151	98+98	23	25	4x ϕ 6+20x ϕ 5.2	4xM5+20xM4	黄铜
	15+15	270	151	121+121	23	25	4x ϕ 6+26x ϕ 5.2	4xM5+26xM4	黄铜
WB6509C	6.5x9	188	102	...	40	31	黄铜
WB0612B	6x12-8P	126	117.5	66.5	31	20	2x ϕ 7+6x ϕ 5	2xM5+6xM4	黄铜
	6x12-10P	126	117.5	79.5	31	20	2x ϕ 7+8x ϕ 5	2xM5+8xM4	黄铜
	6x12-13P	126	117.5	99	31	20	2x ϕ 7+11x ϕ 5	2xM5+11xM4	黄铜
	6x12-16P	174	165.5	118.5	31	20	2x ϕ 7+14x ϕ 5	2xM5+14xM4	黄铜
	6x12-20P	174	165.5	144.5	31	20	2x ϕ 7+18x ϕ 5	2xM5+18xM4	黄铜



WB6509D 接地



WB6509D

G-02 接线端子系列



WB0001A

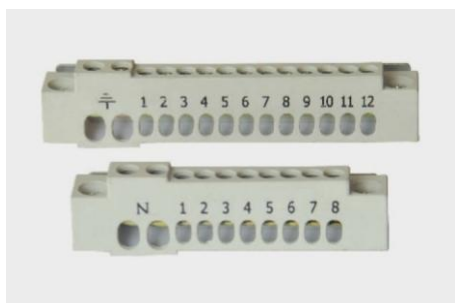
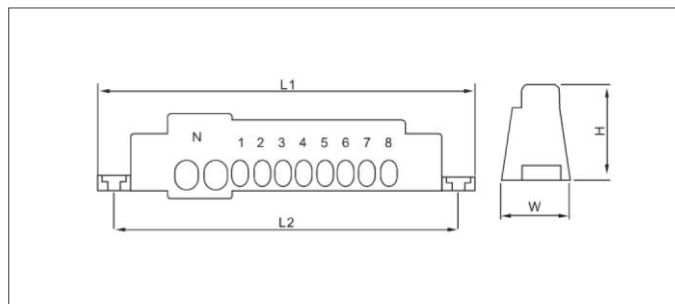

WB0001B

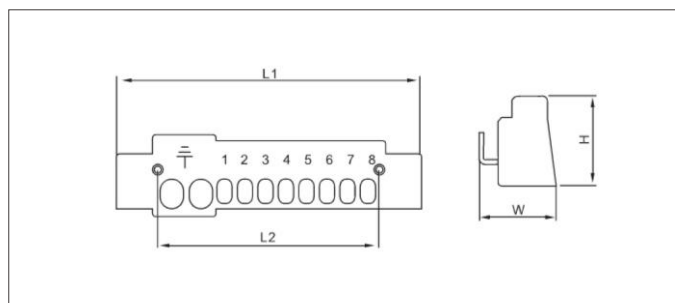

型号	规格	全长 L1	安装孔中心距 L2	高度 H	宽度 W	孔径 ϕ	压线螺丝	材质
WB0001A(TCI型)	6P	105	93	31	22	2x ϕ 8x11+4x ϕ 6x8.5	2xM5+4xM4	黄铜
	8P	120	107	31	22	2x ϕ 8x11+6x ϕ 6x8.5	2xM5+6xM4	黄铜
	10P	135	122	31	22	2x ϕ 8x11+8x ϕ 6x8.5	2xM5+8xM4	黄铜
	12P	150	138	31	22	2x ϕ 8x11+10x ϕ 6x8.5	2xM5+10xM4	黄铜
WB0001B(TCI型)	10P	110	80	30	28	2x ϕ 8x11+8x ϕ 6x8.5	2xM5+8xM4	黄铜
	14P	142	110	30	28	2x ϕ 8x11+12x ϕ 6x8.5	2xM5+12xM4	黄铜
WB0709A接地	6/2	65	56	13	7	6x ϕ 6	6xM5	黄铜
	10/2	96	56	13	7	10x ϕ 6	10xM5	黄铜
	16/2	144	56	13	7	16x ϕ 6	16xM5	黄铜
WB0709A接零	8P	92	79.5	26	19	8x ϕ 6	8xM5	黄铜
	12P	127	115.5	26	19	12x ϕ 6	12xM5	黄铜
	18P	193	180.5	26	19	18x ϕ 6	18xM5	黄铜



WB0709A 接地



WB0709A 接零

G-02 接线端子系列

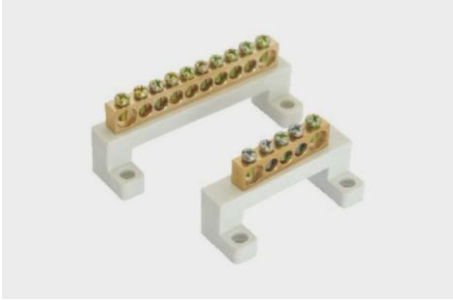

WB0914A

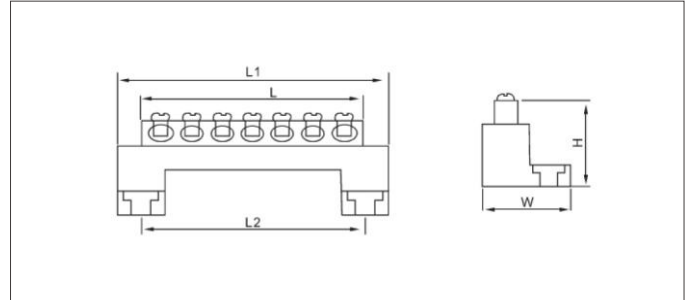

WB0711B

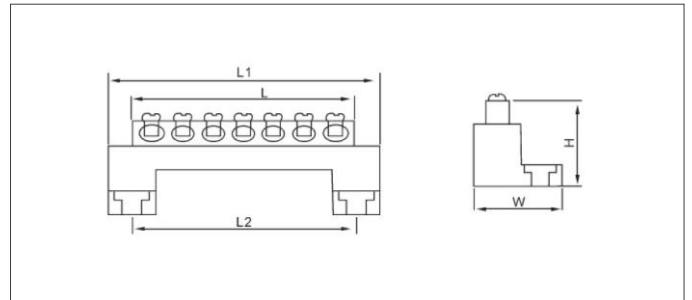

WB0710A(福州型)

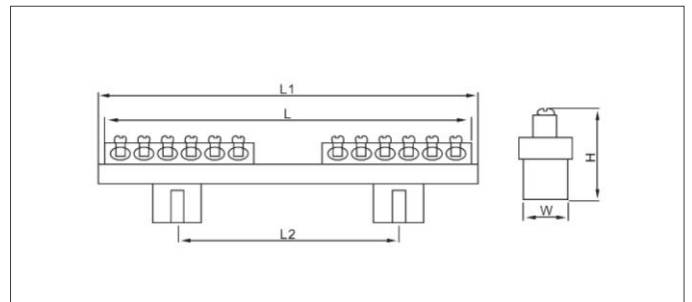

型号	规格	全长 L1	安装孔中心距 L2	铜件长度 L	高度 H	宽度 W	孔径 ϕ	压线螺丝	材质
WB0914A	8x13-5P	74	60	50	43	27	3x ϕ 7+2x ϕ 10	M5	黄铜
	8x13-6P	74	60	58.5	43	27	4x ϕ 7+2x ϕ 10	M5	黄铜
	8x13-7P	74	60	67	43	27	5x ϕ 7+2x ϕ 10	M5	黄铜
	8x13-8P	75.5	60	75.5	43	27	6x ϕ 7+2x ϕ 10	M5	黄铜
	8x13-10P	104	91	92	43	27	8x ϕ 7+2x ϕ 10	M5	黄铜
	8x13-12P	110	91	109	43	27	10x ϕ 7+2x ϕ 10	M5	黄铜
	8x13-15P	137	91	134	43	27	13x ϕ 7+2x ϕ 10	M5	黄铜
8x13-20P	177	91	176	43	27	18x ϕ 7+2x ϕ 10	M5	黄铜	
WB0711B	7x11-5P	74	60	45	42	27	3x ϕ 6.5+2x ϕ 8	M5	黄铜
	7x11-7P	74	60	61	42	27	5x ϕ 6.5+2x ϕ 8	M5	黄铜
	7x11-10P	104	91	84	42	27	8x ϕ 6.5+2x ϕ 8	M5	黄铜
	7x11-15P	124.5	91	125	42	27	13x ϕ 6.5+2x ϕ 8	M5	黄铜
	7x11-20P	164.5	91	165	42	27	18x ϕ 6.5+2x ϕ 8	M5	黄铜
WB0710A(福州型)	7x10-6+6	120	70	116	40	16	ϕ 5.5	M4x9	黄铜

G-02 接线端子系列

G

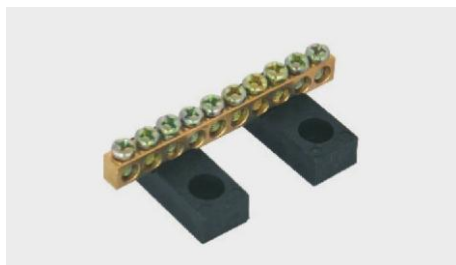

WB0608A

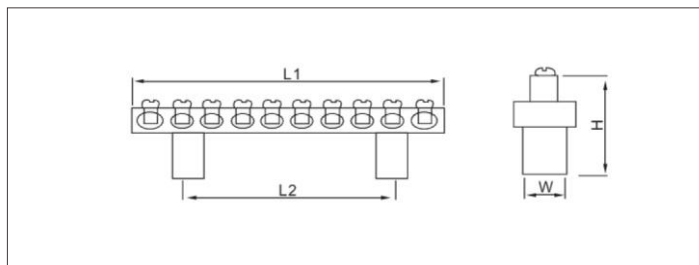

5.5X7.5

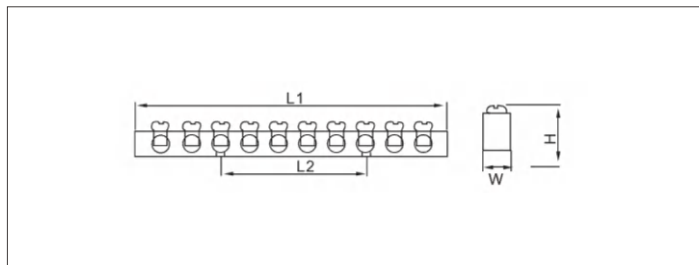

WB0812F

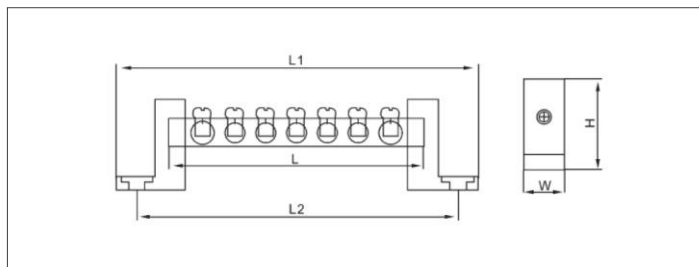

型号	规格	全长 L1	安装孔中心距 L2	铜件长度 L	高度 H	宽度 W	孔径 ϕ	压线螺丝	材质
WB0608A	-3P	20.1	...	20.1	19	31	$\phi 5$	M4	黄铜
	-4P	26.4	...	26.4	19	31	$\phi 5$	M4	黄铜
	-5P	30.6	...	30.6	19	31	$\phi 5$	M4	黄铜
	-6P	38.4	20	38.4	19	31	$\phi 5$	M4	黄铜
	-7P	45.3	...	45.3	19	31	$\phi 5$	M4	黄铜
	-8P	51.2	32	51.2	19	31	$\phi 5$	M4	黄铜
	-10P	64	32	64	19	31	$\phi 5$	M4	黄铜
5.5x7.5	-3P	20.1	...	20.1	11	5.5	$\phi 5$	M4	黄铜
	-4P	26.4	...	26.4	11	5.5	$\phi 5$	M4	黄铜
	-5P	30.6	...	30.6	11	5.5	$\phi 5$	M4	黄铜
	-6P	38.4	19.2	38.4	11	5.5	$\phi 5$	M4	黄铜
	-7P	45.3	...	45.3	11	5.5	$\phi 5$	M4	黄铜
	-8P	51.2	32	51.2	11	5.5	$\phi 5$	M4	黄铜
	-10P	64	32	64	11	5.5	$\phi 5$	M4	黄铜
WB0812F	7x10-3P	58	49	33	40	15	2x $\phi 6.5$ +1x $\phi 7.5$	M5	黄铜
	7x10-4P	65	55	40.3	40	15	3x $\phi 6.5$ +1x $\phi 7.5$	M5	黄铜
	7x10-5P	75	65	49	40	15	3x $\phi 6.5$ +2x $\phi 7.5$	M5	黄铜
	7x10-6P	83	72.5	56.2	40	15	4x $\phi 6.5$ +2x $\phi 7.5$	M5	黄铜
	7x10-7P	88	79	64	40	15	5x $\phi 6.5$ +2x $\phi 7.5$	M5	黄铜
	7x10-8P	95.5	86	71.5	40	15	6x $\phi 6.5$ +2x $\phi 7.5$	M5	黄铜
	7x10-10P	110	101.5	86.3	40	15	8x $\phi 6.5$ +2x $\phi 7.5$	M5	黄铜
	7x10-12P	125.5	116.5	101.1	40	15	10x $\phi 6.5$ +2x $\phi 7.5$	M5	黄铜
	7x10-15P	148	138.5	123.5	40	15	13x $\phi 6.5$ +2x $\phi 7.5$	M5	黄铜
	7x10-20P	186	177	162	40	15	18x $\phi 6.5$ +2x $\phi 7.5$	M5	黄铜

G-02 接线端子系列



WB0710B

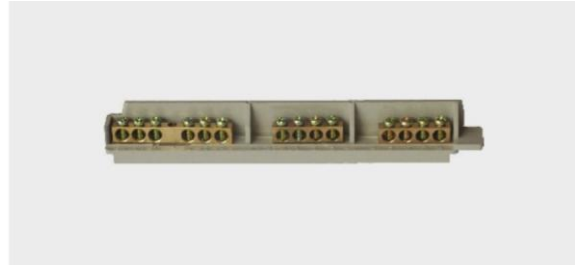

WB0002A(6+4+4)

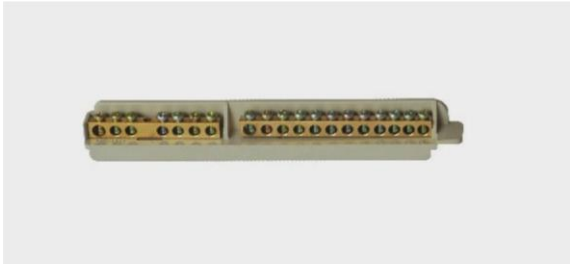

WB0002A(7+12)

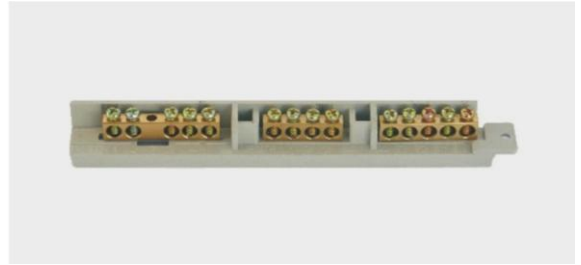

WB0002A(5+4+5)

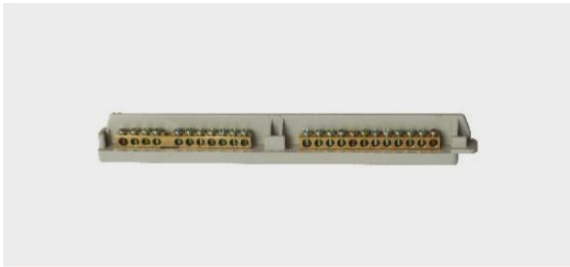

WB0002A(12+12)

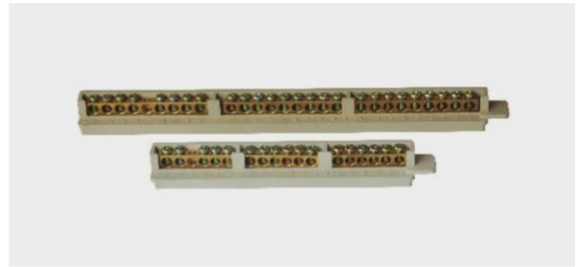

WB0710C

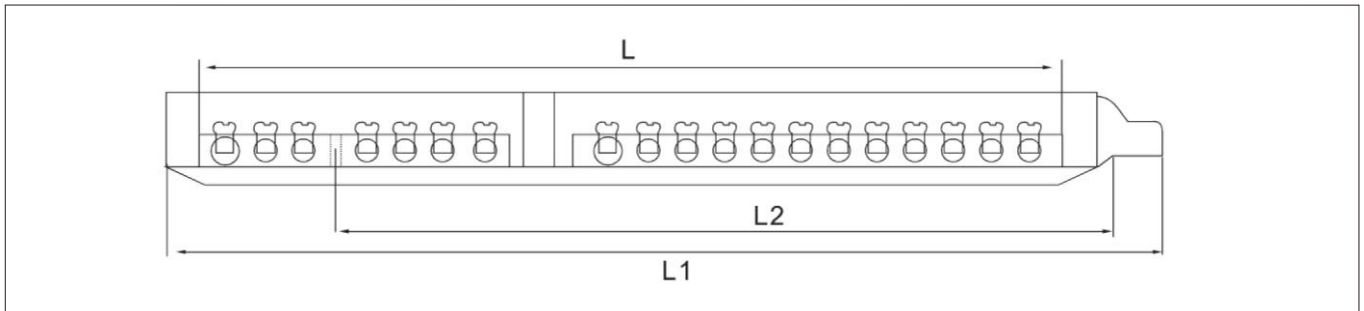

型号	规格	全长 L1	安装孔中心距 L2	铜件长度 L	高度 H	宽度 W	孔径 ϕ	压线螺丝	材质
WB0710B	6+6	112.5	76	100	20	20	2x ϕ 6.5+10x ϕ 6	M4	黄铜
	9+9	175	122	163	20	20	2x ϕ 6.5+16x ϕ 5.5	M4	黄铜
WB0002A	6+4+4	180	141	169	25	18	14x ϕ 6.5	M4	黄铜
	7+12	180	143.5	169	25	18	2x ϕ 6.5+17x ϕ 5.5	M4	黄铜
	5+4+5	171	131.5	165	20	18	14x ϕ 6.5	M4	黄铜
	12+12	250	200	238	30	18	2x ϕ 6.5+21x ϕ 5.5	M4	黄铜
WB0710C	6+6+6	161	125	149	20	20	3x ϕ 6.5+15x ϕ 5.5	M4	黄铜
	9+9+9	255	202	243	20	20	3x ϕ 6.5+24x ϕ 5.5	M4	黄铜

G-02 接线端子系列

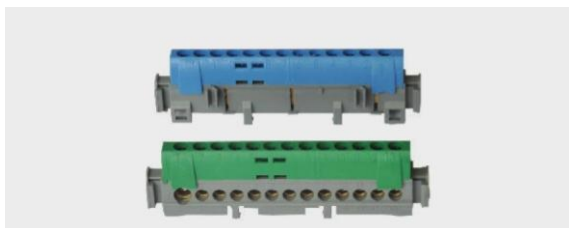

WB6595A



WB6509B

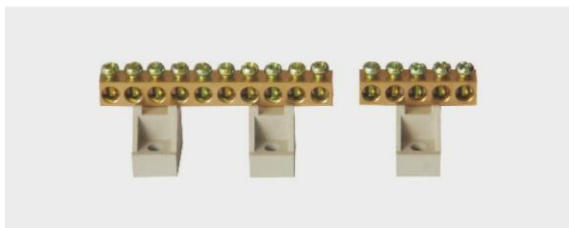

WB0909A

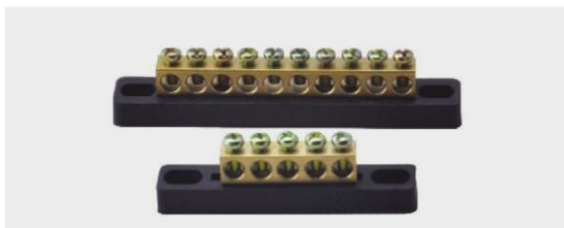

WB0909B



WB0610G

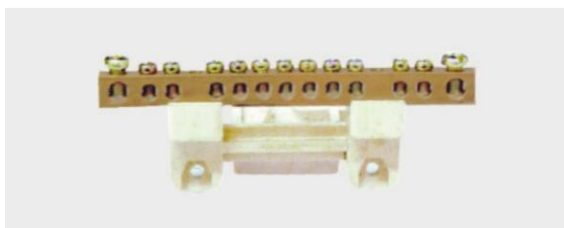

WB6509A



WB0210A

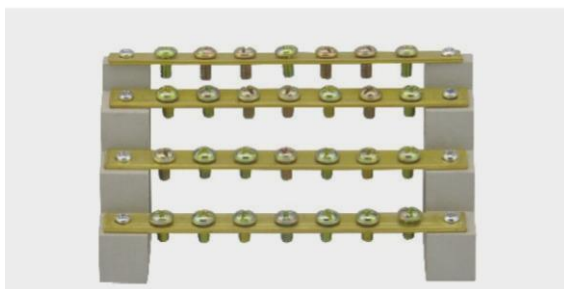

WB0210B

型号	规格	全长 L1	安装孔中心距 L2	铜件长度 L	高度 H	宽度 W	孔径 ϕ	压线螺丝	材质
WB0610G	5P	83	72	39	35	13	1x ϕ 6.5+4x ϕ 5	M4	黄铜
	6P	83	72	46	35	13	1x ϕ 6.5+5x ϕ 5	M4	黄铜
	7P	83	72	53	35	13	1x ϕ 6.5+6x ϕ 5	M4	黄铜
WB0909A	5P	37.5	...	37.5	29	31.5	ϕ 5.5	M4	黄铜
	10P	75	52.5	75	29	31.5	ϕ 5.5	M4	黄铜
WB6509A	13P	60	46	60	M4	黄铜
WB0909B	5P	73	58	37.5	21	15	ϕ 5.5	M4	黄铜
	10P	103	88	75	21	15	ϕ 5.5	M4	黄铜
WB0210A	4P	85	71	83	40	30	...	M4	黄铜
	5P	95	81	91	40	30	...	M4	黄铜
	7P	119	105	115	40	30	...	M4	黄铜
	9P	144	130	140	40	30	...	M4	黄铜
WB0210B	4P	85	71	83	65	50	...	M4	黄铜
	5P	95	81	91	65	50	...	M4	黄铜
	7P	119	105	115	65	50	...	M4	黄铜
	9P	144	130	140	65	50	...	M4	黄铜

G-03 铜端子系列



6x9 8/1

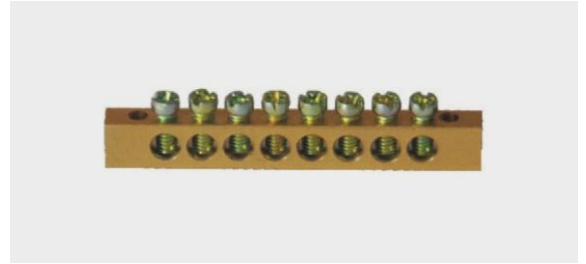

6x9 8/2

型号	规格	全长 L1	安装孔中心距 L2	高度 H	宽度 W	孔径 ϕ	压线螺丝	材质
6x9	8/1	57.6	...	12.5	6	$\phi 5$	M4	黄铜
	10/1	70	...	12.5	6	$\phi 5$	M4	黄铜
	12/1	82.4	...	12.5	6	$\phi 5$	M4	黄铜
	14/1	94.8	...	12.5	6	$\phi 5$	M4	黄铜
	20/1	132	...	12.5	6	$\phi 5$	M4	黄铜
	24/1	156.8	...	12.5	6	$\phi 5$	M4	黄铜
	8/2	63.8	55.8	12.5	6	$\phi 5$	M4	黄铜
	10/2	76.2	68.2	12.5	6	$\phi 5$	M4	黄铜
	12/2	88.6	80.6	12.5	6	$\phi 5$	M4	黄铜
	14/2	101	93	12.5	6	$\phi 5$	M4	黄铜
	20/2	138.2	130.2	12.5	6	$\phi 5$	M4	黄铜
	24/2	163	155	12.5	6	$\phi 5$	M4	黄铜

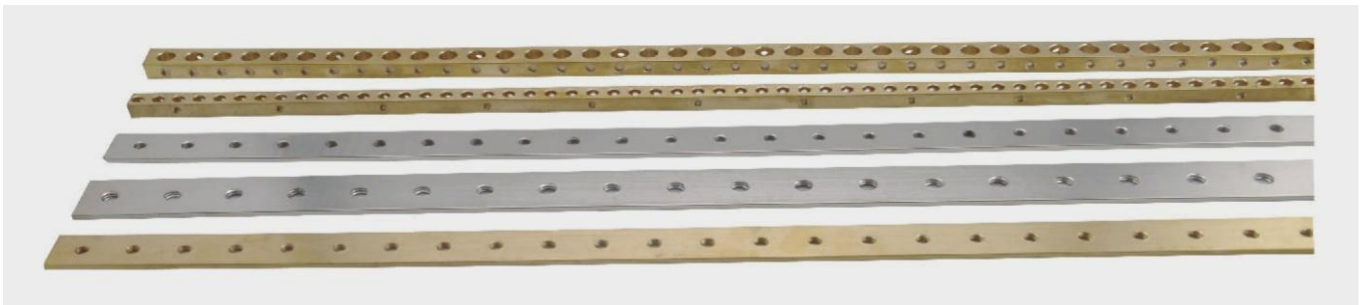

规格	孔径 ϕ	螺纹	规格	孔径 ϕ	螺纹
6x8x1米	$\phi 5$	M4	12x12x1米	$\phi 6$	M5
6x9x1米	$\phi 5$	M4	14x14x1米	$\phi 8$	M5
7x9x1米	$\phi 5$	M4	12x18x1米(单排)	$\phi 10$	M6
8x8x1米	$\phi 5$	M4	12x18x1米(双排)	$\phi 6$	M5
9x9x1米	$\phi 5$	M4	2x10x1米	...	M4
8x10x1米	$\phi 5$	M4	3x15x1米	...	M5
10x10x1米	$\phi 5.5$	M4	3x20x1米	...	M6
8x12x1米	$\phi 6$	M4	3x25x1米	...	M8
9x14x1米	$\phi 8$	M5	3x30x1米	...	M8
10x12x1米	$\phi 6$	M5	4x40x1米	...	M8

G-03 铜端子系列

G



6X10

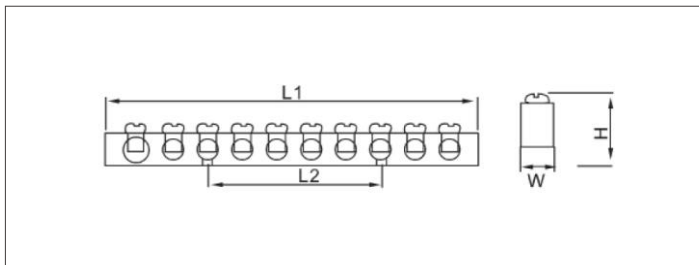

7X11

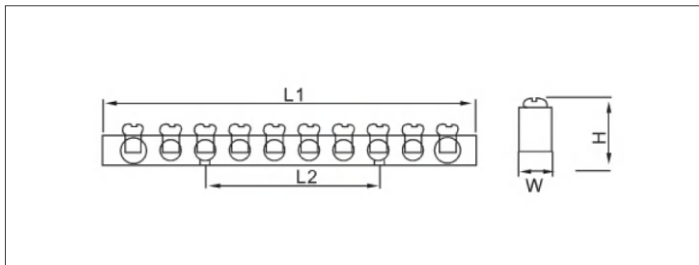

8X13

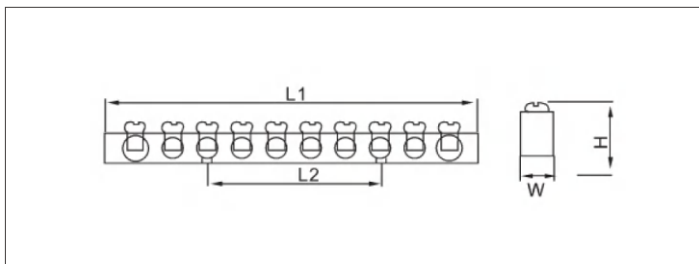

型号	规格	全长 L1	安装孔中心距 L2	高度 H	宽度 W	孔径 ϕ	压线螺丝	材质
6x10	4P	30	21	14	6	4x $\phi 5$	M4	黄铜
	5P	39	21	14	6	1x $\phi 6.5$ +4x $\phi 5$	M4	黄铜
	6P	46	21	14	6	1x $\phi 6.5$ +5x $\phi 5$	M4	黄铜
	7P	53	30	14	6	1x $\phi 6.5$ +6x $\phi 5$	M4	黄铜
	8P	60	35	14	6	1x $\phi 6.5$ +7x $\phi 5$	M4	黄铜
	10P	74	50	14	6	1x $\phi 6.5$ +9x $\phi 5$	M4	黄铜
	12P	89	64	14	6	1x $\phi 6.5$ +11x $\phi 5$	M4	黄铜
	14P	103	80	14	6	1x $\phi 6.5$ +13x $\phi 5$	M4	黄铜
	15P	110	43	14	6	1x $\phi 6.5$ +14x $\phi 5$	M4	黄铜
7x11	5P	45	16	15	7	2x $\phi 8$ +3x $\phi 6.5$	M5	黄铜
	6P	52	24	15	7	2x $\phi 8$ +4x $\phi 6.5$	M5	黄铜
	7P	61	32	15	7	2x $\phi 8$ +5x $\phi 6.5$	M5	黄铜
	8P	67.5	38	15	7	2x $\phi 8$ +6x $\phi 6.5$	M5	黄铜
	10P	84	40	15	7	2x $\phi 8$ +8x $\phi 6.5$	M5	黄铜
	12P	100.1	40	15	7	2x $\phi 8$ +10x $\phi 6.5$	M5	黄铜
	15P	124.5	48	15	7	2x $\phi 8$ +13x $\phi 6.5$	M5	黄铜
	20P	164.5	56	15	7	2x $\phi 8$ +18x $\phi 6.5$	M5	黄铜
8x13	5P	50	17	17.5	8	2x $\phi 10$ +3x $\phi 7$	M5	黄铜
	6P	58.5	25.5	17.5	8	2x $\phi 10$ +4x $\phi 7$	M5	黄铜
	7P	67	34	17.5	8	2x $\phi 10$ +5x $\phi 7$	M5	黄铜
	8P	75.5	42.5	17.5	8	2x $\phi 10$ +6x $\phi 7$	M5	黄铜
	10P	92	42.5	17.5	8	2x $\phi 10$ +8x $\phi 7$	M5	黄铜
	12P	109	42.5	17.5	8	2x $\phi 10$ +10x $\phi 7$	M5	黄铜
	15P	134	51	17.5	8	2x $\phi 10$ +13x $\phi 7$	M5	黄铜
	20P	175.6	59.5	17.5	8	2x $\phi 10$ +18x $\phi 7$	M5	黄铜

G-03 铜端子系列



JDG-A型

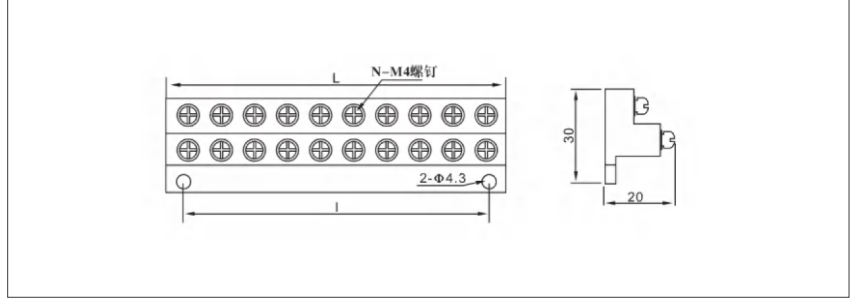

JDG-B型

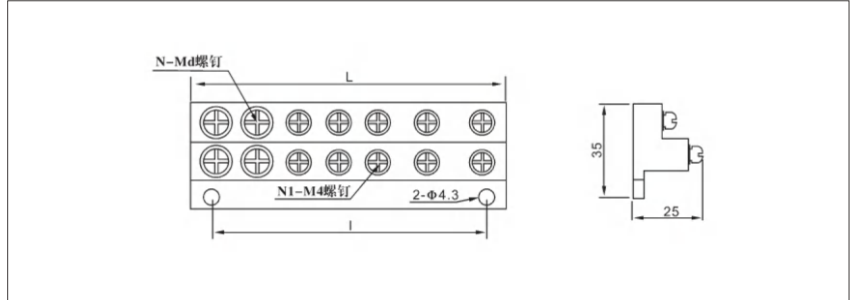

型号规格	N	外形尺寸(mm)		型号规格	N	外形尺寸(mm)	
		l	l			l	l
JDG-A-1(2节)	4	20	10	JDG-A-6(7节)	14	70	60
JDG-A-2(3节)	6	30	20	JDG-A-7(8节)	16	80	70
JDG-A-3(4节)	8	40	30	JDG-A-8(9节)	18	90	80
JDG-A-4(5节)	10	50	40	JDG-A-9(10节)	20	100	90
JDG-A-5(6节)	12	60	50

型号规格	D	N	NI	外形尺寸(mm)		型号规格	D	N	NI	外形尺寸(mm)	
				l	l					L	l
JDG-B-1	M5	4	4	48	38	JDG-B-11	M5	6	4	62	52
JDG-B-2			6	58	48	JDG-B-12			6	72	62
JDG-B-3			10	78	68	JDG-B-13			10	92	82
JDG-B-4			14	98	88	JDG-B-14			14	112	102
JDG-B-5			18	118	108	JDG-B-15			18	132	122
JDG-B-6	M6	4	4	48	38	JDG-B-16	M6	6	4	62	52
JDG-B-7			6	58	48	JDG-B-17			6	72	62
JDG-B-8			10	78	68	JDG-B-18			10	92	82
JDG-B-9			14	98	88	JDG-B-19			14	112	102
JDG-B-10			18	118	108	JDG-B-20			18	132	122

G-03 铜端子系列



JDG-C型

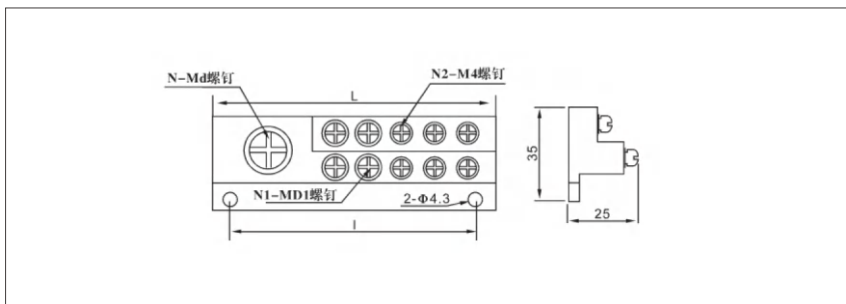

JDG-D型

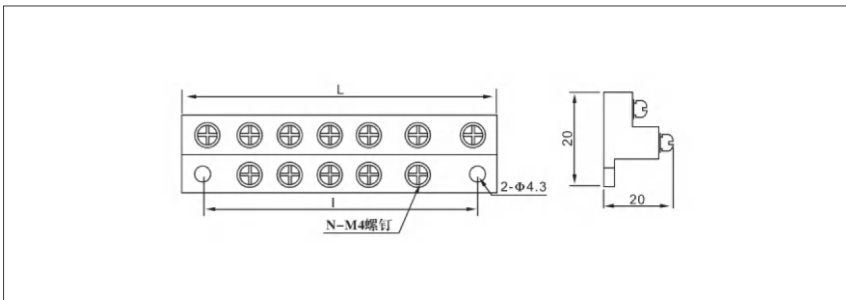

型号规格	D	N	D1	N1	N2	外形尺寸(mm)		型号规格	D	N	D1	N1	N2	外形尺寸(mm)	
						l	l							l	l
JDG-C-1	M8	1	M5	4	2	58	48	JDG-C-9	M8	2	M5	6	2	92	82
JDG-C-2					6	78	68	JDG-C-10					6	112	102
JDG-C-3					10	98	88	JDG-C-11					10	132	122
JDG-C-4					14	118	108	JDG-C-12					14	152	142
JDG-C-5	M10	1	M6	4	2	58	48	JDG-C-13	M10	2	M6	6	2	92	82
JDG-C-6					6	78	68	JDG-C-14					6	112	102
JDG-C-7					10	98	88	JDG-C-15					10	132	122
JDG-C-8					14	118	108	JDG-C-16					14	152	142

型号规格	N	外形尺寸(mm)		型号规格	N	外形尺寸(mm)	
		L	l			L	l
JDG-D-1(2节)	2	20	10	JDG-D-5(6节)	10	60	50
JDG-D-2(3节)	4	30	20	JDG-D-6(7节)	12	70	60
JDG-D-3(4节)	6	40	30	JDG-D-7(8节)	14	80	70
JDG-D-4(5节)	8	50	40	JDG-D-9(10节)	18	100	90

G-03 铜端子系列

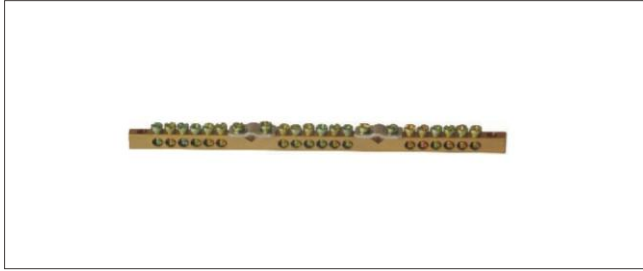

WB6509V



WB0410A 4X10X55

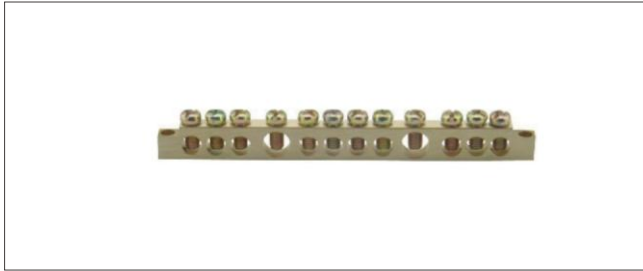

WB0612A

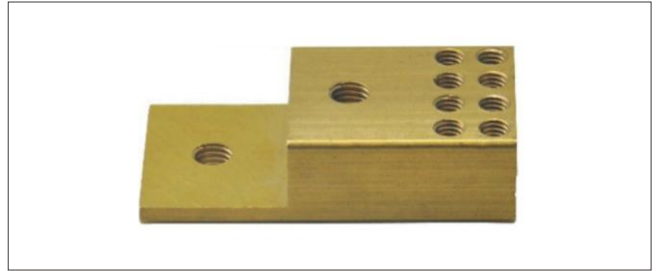

20X34X69



9X9铜件

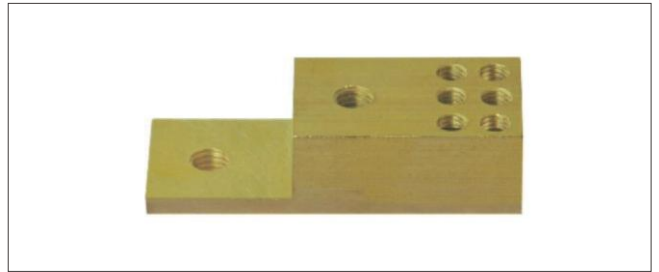

20X27X69

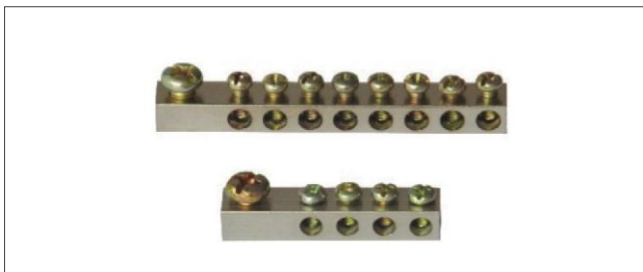

9X9铜件带头

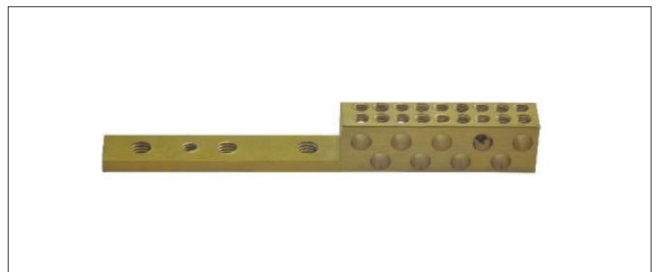

16X20X150



WB0812A

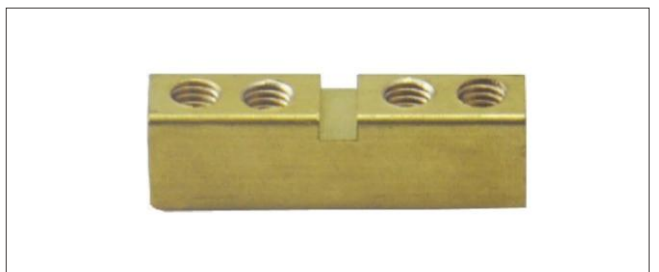

9.5X13X42

G-03 铜端子系列

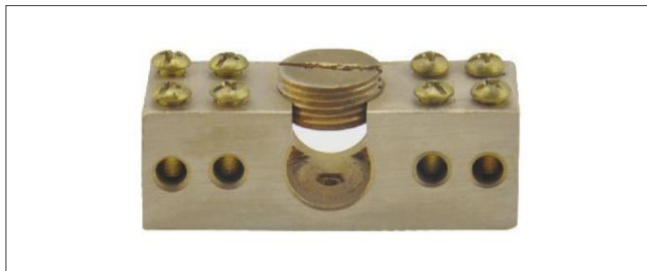

WFB-10



WFB-1



WFB-2

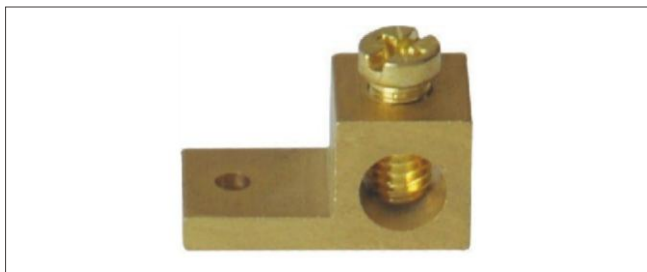

WFB-3

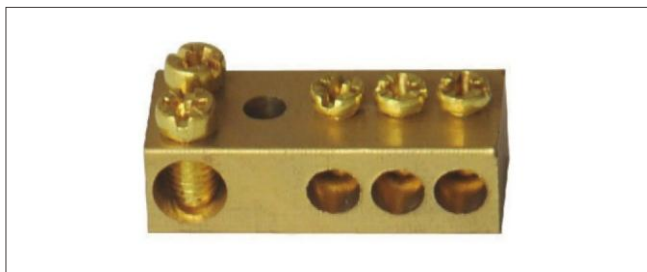

WFB-4

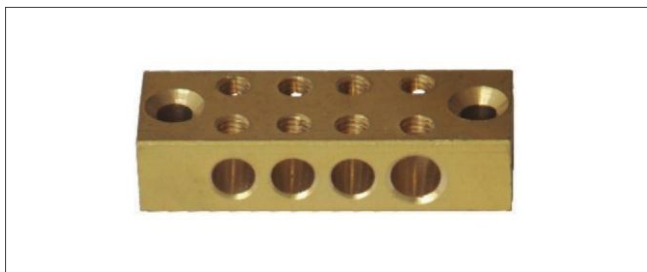

WFB-5

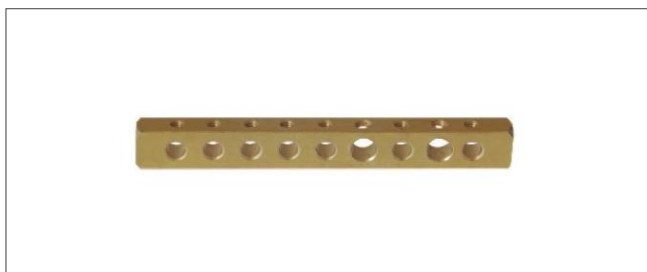

WFB-6



WFB-7

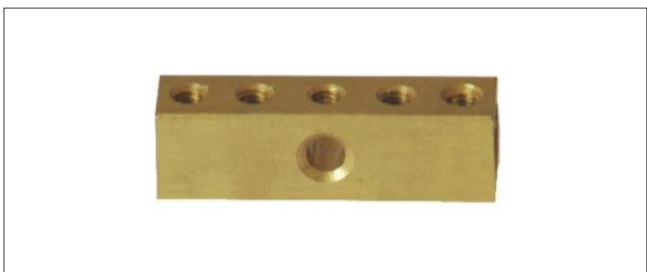

WFB-8

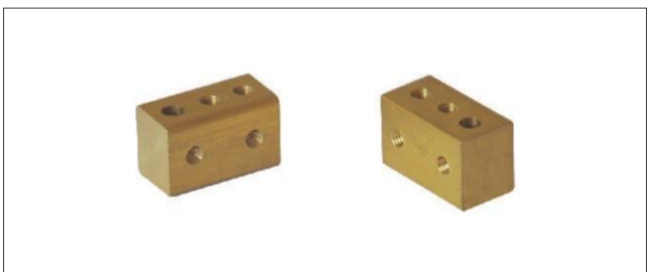

WFB-9

G-04 绝缘支架系列



WP 01



WP 02



WP 03



WP 04



WP 05

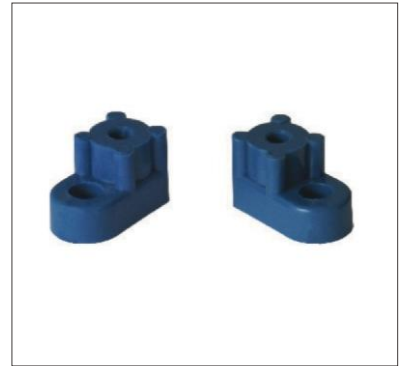

WP 06

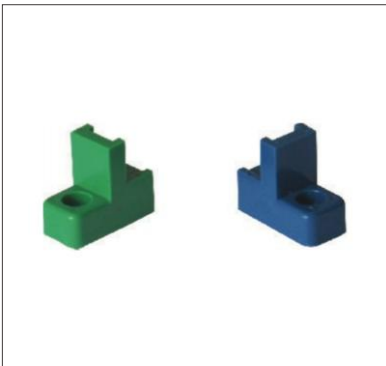

WP 07



WP 08



WP 09



WP 010

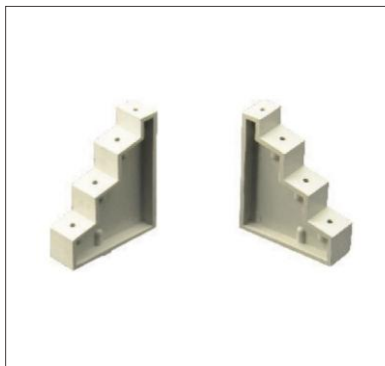

WP 011



WP 012

G-05 HLPT 汇流排系列

型号 Type	C45/1P
材质 Material	紫铜
厚x宽 Thickness width(mm)	1.0x5(32A)、1.2x5(40A)、1.4x5(50A) 1.4x7(63A)、1.7x7(63A)、1.7x9(80A)1.9x9(100A)
长度 Length	1000mm(特殊长度可定制)
间距	18mm

型号 Type	C45/1P+L (带漏电)
材质 Material	紫铜
厚x宽 Thickness width(mm)	1.0x5(32A)、1.2x5(40A)、1.4x5(50A)、 1.4x7(63A)、1.7x9(80A)
长度 Length	1000mm(特殊长度可定制)
间距	45mm

型号 Type	C45/2P
材质 Material	紫铜
厚x宽 Thickness width(mm)	1.0x5(32A)、1.2x5(40A)、1.4x5(50A) 1.4x7(63A)、1.7x7(63A)、1.7x9(80A)1.9x9(100A)
长度 Length	1000mm(特殊长度可定制)
间距	36mm

型号 Type	C45/2P+L (带漏电)
材质 Material	紫铜
厚x宽 Thickness width(mm)	1.0x5(32A)、1.2x5(40A)、1.4x5(50A) 1.4x7(63A)、1.7x9(80A)
长度 Length	1000mm(特殊长度可定制)
间距	63mm

型号 Type	C45/3P
材质 Material	紫铜
厚x宽 Thickness width(mm)	1.0x5(32A)、1.2x5(40A)、1.4x5(50A) 1.4x7(63A)、1.7x7(63A)、1.7x9(80A) 1.9x9(100A)、3.0x9(150A)
长度 Length	1000mm(特殊长度可定制)
间距	54mm

型号 Type	C45/3P+L (带漏电)
材质 Material	紫铜
厚x宽 Thickness width(mm)	1.4x7(63A)
长度 Length	1000mm(特殊长度可定制)
间距	99mm

型号 Type	C45/4P
材质 Material	紫铜
厚x宽 Thickness width(mm)	1.2x5(40A)、1.4x7(63A)、1.7x9(80A) 1.9x9(100A)
长度 Length	1000mm(特殊长度可定制)
间距	72mm

型号 Type	C45/4P+L (带漏电)
材质 Material	紫铜
厚x宽 Thickness width(mm)	1.4x7(63A)
长度 Length	1000mm(特殊长度可定制)
间距	117mm

G-06 模数化插座

AC30模数插座适用于交流50HZ，额定工作电压至440V，额定电流不超过32A的电路中。

主要用于家庭、办公、农场、轻工业等场所，可供非专业人员使用，而且大多数情况下与电气及设备相连。

AC30模数化插座具有良好的接触可靠性，适合于导轨安装，并能与其它模数化终端子电器配合使用。

AC30 modular socket is suitable for circuits with AC 50 Hz, rated working voltage up to 440 V and rated current no more than 32A.

It is mainly used in home, office, farm, light industry and other places. It can be used by non professionals and is connected with electrical and equipment in most cases.

AC30 modular socket has good contact reliability, which is suitable for installation of guide rail and can be used with other modular terminal electrical appliances.

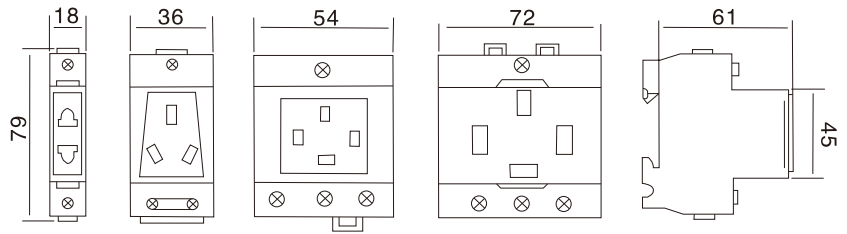

型号	额定电压、额定电流	宽度	占回路数
AC30二插	220V/10A	18	1
AC30三插	220V/10A	36	2
AC30三插	220V/16A	36	2
AC30三插	380V/25A	45	2.5
AC30四插	380V/16A	54	3
AC30四插	380V/25A	72	4

G-07 高压连接片

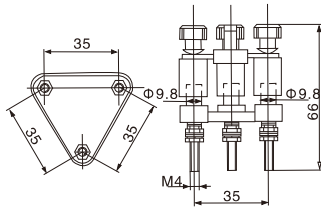

型号 Item

JL1-2.5/3

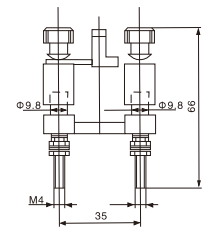

型号 Item

JL1-2.5/2

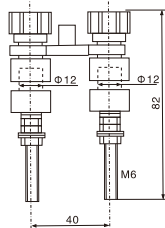

型号 Item

试验型单连接SD-10

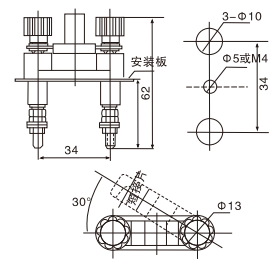

型号 Item

JY1-2

G-09 计量箱零地排

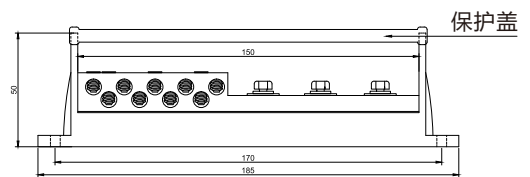
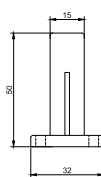
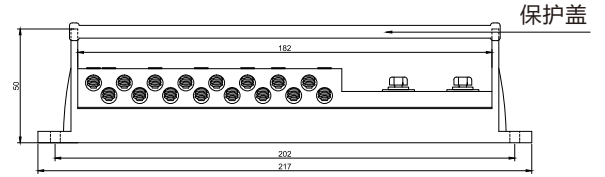
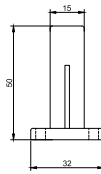
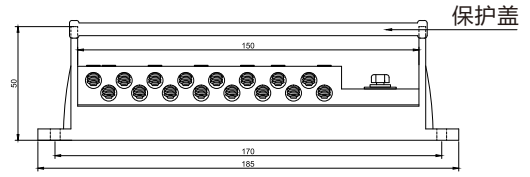
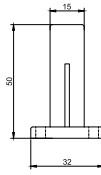

规格	全长	安装孔中心距	铜件长度	铜件高度	高度	宽度	孔径 ϕ	压线螺丝	材质
DLP1-16	185	170	150	17	50	15	$\phi 7.5$	M5	黄铜
DLP2-16	217	202	178	17	50	15	$\phi 7.5$	M5	黄铜
DLP3-9	185	170	150	17	50	15	$\phi 7.5$	M5	黄铜

G-10 铜编织带

产品介绍：采用纯铜丝精编而成，柔软度极佳，具有良好的导电性和抗氧化性，起接地，导电，屏蔽，抗干扰的作用。

产品应用：应用于汽车，地铁，高铁，航天，机械设备和电子线材上。

材质：纯铜丝

尺寸：4-28MM

工作温度：-40°-150°C

颜色：镀锡铜，铜本色

认证：SGS

Product introduction: It is made of pure copper wire, with excellent softness, good conductivity and oxidation resistance, and plays the role of grounding, conduction, shielding and anti-interference.

Product application: used in automobiles, subways, high-speed rail, aerospace, mechanical equipment and electronic wires.

Material: Pure copper wire

Size: 4-28MM

Working temperature: -40°-150°C

Color: tinned copper, copper

Certification: SGS



截面(mm ²)	股数X根数X套数/单线直径	宽度(mm)	厚度(mm)	1米重量(kg)
1.5	24X4X1/0.15	4	1.0	0.015
2.5	24X6X1/0.15	5	1.0	0.025
4	24X10X1/0.15	8	1.0	0.04
6	36X10X1/0.15	12	1.2	0.06
8	48X10X1/0.15	15	1.5	0.08
10	48X12X1/0.15	18	1.4	0.102
12	48X15X1/0.15	20	1.8	0.125
16	48X20X1/0.15	22	2.0	0.170
20	48X25X1/0.15	25	2.0	0.2
25	48X30X1/0.15	28	2.5	0.254
35	48X20X2/0.15	26	3.2	0.310
50	48X30X2/0.15	28	4.8	0.509



线槽 | 智能照明灯 | 冷压端子 | 端子台 | 导轨 | 管件接头 | 地零排 | 绝缘母线夹 | 拖链 | 结束带
 编织网管 | 热缩管 | Pu气管 | 扣件保护 | 标识类 | 航空插头 | 重载连接器 | 工具系列 | 风机系列

Wenbuluo

江苏稳不落配线器材有限公司
 Wenbuluo Electrical Co., Ltd

☎ 0512-36602880

🌐 www.wenbuluo.com www.wenbuluo.cn

📍 江苏省苏州市昆山市开发区熊庄路25号